

4TH STREET ROAD/CTH T
SANITARY SEWER RELOCATION
PROJECT MANUAL

TOWN OF EMPIRE
FOND DU LAC COUNTY, WISCONSIN

Owner:
Empire Sanitary District No. 3
Attn: Norb Kolell
W6254 Creek Road
Fond du Lac WI 54935

PROJECT NO. 775.005

December 5, 2024

Prepared by
Eric R. Otte, P.E., P.L.S.
J E Arthur and Associates, Inc.
Engineers • Surveyors
548 Prairie Road
Fond du Lac, WI 54935
Telephone: (920) 922-5703

This page was intentionally left blank.

(Blank)

TABLE OF CONTENTS

	<u>PART</u>	<u>PAGE</u>
TABLE OF CONTENTS	i	
BIDDING INFORMATION	1	
Advertisement for Bid		1-1
Information to Bidders		1-2
BID FORMS	2	
Bid		2-1
Bidder's Certificate		2-2
Affidavit of Bidder		2-3
List of Subcontractors		2-4
Bid Bond		2-5
AGREEMENT FORMS	3	
Agreement		3-1
Performance Bond		3-2
Certificate of Insurance		3-3
MISCELLANEOUS FORMS	4	
Notice of Award		4-1
Notice to Proceed		4-2
Change Order		4-3
GENERAL CONDITIONS	5	
Standard General Conditions of the Construction Contract, ACEC		
SUPPLEMENTARY CONDITIONS	6	6-1
GENERAL SPECIFICATIONS	7	7-1
SPECIAL SPECIFICATIONS	8	8-1
SEWER CONSTRUCTION	10	10-1
TOPSOIL	23	23-1
SEEDING	24	24-1

ADVERTISEMENT FOR BIDS

TOWN OF EMPIRE SANITARY DISTRICT NO. 3
SANITARY SEWER RELOCATION
TOWN OF EMPIRE, FOND DU LAC COUNTY, WISCONSIN

Notice is hereby given that sealed proposals for the following WORK will be received on behalf of Empire Sanitary District No. 3 until **2:00 P.M., February 10, 2025 at the offices of J.E. Arthur and Associates, Inc.**, at which time and place such proposals will be publicly opened and read. Action on the award is expected to be taken at a special Sanitary District meeting scheduled for February 11, 2025.

Principal items of construction include:

1. 73 L.F. 8" PVC Sanitary Sewer
2. 29 V.F. 4' Diameter Sanitary Manhole
3. 3 Ea. Adjust Sanitary Manhole

The CONTRACT DOCUMENTS, including DRAWINGS and SPECIFICATIONS, may be obtained at the offices of J.E. Arthur and Associates, Inc., 548 Prairie Road, Fond du Lac, Wisconsin 54935, upon the deposit of twenty-five dollars (\$25.00) for plans and specification book each set. If CONTRACT DOCUMENTS are to be mailed, include a separate, non-returnable fee of \$15.00 for postage and handling charges. The deposit will be refunded to those parties returning the CONTRACT DOCUMENTS, including DRAWINGS and SPECIFICATIONS, in good condition not later than ten days after the opening of the BIDS. Alternately, the BIDDING DOCUMENTS can be emailed in pdf format free of charge. Each proposal shall be submitted on the standard proposal form included in the CONTRACT DOCUMENTS. **The entire CONTRACT DOCUMENTS** shall be enclosed in a sealed envelope and endorsed on the outside: "TOWN OF EMPIRE SD#3 SANITARY SEWER RELOCATION."

Each proposal will be accompanied by a certified check or bank draft payable to the Sanitary District, or a satisfactory BID BOND in an amount of not less than five percent (5%) of the BID as a guarantee that if the proposal is accepted, a CONTRACT will be entered into and the performance of the CONTRACT is properly secured.

The letting of the above-described WORK is subject to the provisions of Section 66.0901 of the Wisconsin Statutes.

The successful BIDDER will be required to furnish a satisfactory PERFORMANCE BOND in the sum of the full amount of the CONTRACT(S).

No BID shall be withdrawn after the opening of BIDS without the consent of the District for a period of forty-five (45) days after the scheduled time of closing BIDS.

The District reserves the right to reject any or all BIDS, to waive any informalities in bidding and select the BIDS that will best serve the interests of the District.

Published by authority of the Town of Empire Sanitary District No. 3 on January 27th and February 3rd, 2025.

Jeff Timler, Clerk-Treasurer
Town of Empire SD#3

This page was intentionally left blank.

INSTRUCTIONS FOR BIDDERS

1. SOLICITATION OF BIDS

- 1.1. BIDS are solicited by the OWNER for the construction project named in the ADVERTISEMENT FOR BIDS and must be submitted at the time and place indicated in the ADVERTISEMENT FOR BIDS. The WORK includes the construction WORK stipulated in the ADVERTISEMENT FOR BIDS and as shown on the attached DRAWINGS and SPECIFICATIONS.

2. QUALIFICATION OF BIDDER

- 2.1. BIDDER'S proof of responsibility will be required if so stated in the ADVERTISEMENT FOR BIDS. The OWNER may take such investigations as he deems necessary to determine the ability of the BIDDER to perform the WORK, and the BIDDER shall furnish to the OWNER all such information and data for this purpose as the OWNER may request. The OWNER reserves the right to reject any BID if the evidence submitted by, or investigation of, such BIDDER fails to satisfy the OWNER that such BIDDER is properly qualified to carry out the obligations of the AGREEMENT and to complete the WORK contemplated therein.

3. EXAMINATIONS OF SITE AND CONTRACT DOCUMENTS

- 3.1. BIDDERS shall inform themselves of the conditions under which the WORK is to be performed, concerning the site of the WORK, the structure of the ground, the obstacles which may be encountered, and all other relevant matters concerning the WORK to be performed. The CONTRACTOR to whom a CONTRACT is awarded shall not be allowed any extra compensation by reason of his failure to inform himself of any matter or thing prior to bidding.
- 3.2. The BIDDER is expected to base his BID on materials and equipment complying fully with the CONTRACT DRAWINGS and SPECIFICATIONS. In the event he names or includes in his BID, material or equipment which does not conform, he will, if awarded a CONTRACT, be responsible for furnishing materials and equipment which fully conforms at no change in his CONTRACT PRICE.
- 3.3. BIDDERS must satisfy themselves by personal examination and by such other means as they prefer as to the correctness of any quantities listed the BID and shall not after submission of their BIDS assert that there was any misunderstanding in regard to the amount of WORK to be done.
- 3.4. Before submitting a BID each CONTRACTOR should read the complete CONTRACT DOCUMENTS, including ADVERTISEMENT, INSTRUCTIONS TO BIDDERS, AGREEMENT and SPECIFICATIONS, all of which contain provisions applicable not only to the successful BIDDER but also to any of his SUBCONTRACTORS.
- 3.5. The CONTRACT DOCUMENTS contain the provisions required for the construction of the PROJECT. Information obtained from an officer, agent, or employee of the OWNER or any other person shall not affect the risks or obligations assumed by the CONTRACTOR or relieve him from fulfilling any of the conditions of the CONTRACT.

4. TIME OF COMPLETION

- 4.1. The BIDDER shall include in his BID, a statement of the number of calendar days which he will require for completion of the project after being authorized by the OWNER to proceed.

For the purpose of computing the calendar days for completion, the date of award of CONTRACT shall be considered the starting date for any CONTRACTS in which a starting date is not stipulated by the OWNER on the BID form.

- 4.2. In estimating the time necessary for completing the WORK, the BIDDER shall make allowance for all of the ordinary delays and hindrances incident to such WORK, whether growing out of delays in securing materials, workmen or otherwise. Only delays caused by changes or extensions of plans, by fire, lightning, earthquake, tornado, cyclone, riot, insurrection or war, or by abandonment of the WORK by workmen engaged thereon through no fault of the CONTRACTOR, or by delay occasioned by the discharge of all or any material number of workmen in consequence of difficulties arising between the CONTRACTOR and such workmen will be considered as a basis of extension of time by the OWNER, and only then if supported by written request filed with the OWNER within ten (10) days of the occurrence of the incident causing delay.

5. WAGE RATES

- 5.1. The letting of the proposed PROJECT is **not** subject to the provisions of Section 66.0903 of the Wisconsin Statutes.

6. SALES TAX EXEMPTION

- 6.1. Equipment and material used for pollution abatement is exempt from sales tax, but this applies only to equipment and material used in the central wastewater treatment plants which actually treats the sewage. Approval for the tax exemption must come from the Department of Revenue. CONTRACTOR must supply forms to material seller for exemption.

7. PREPARATION OF BIDS

- 7.1. Each BID must be submitted on the standard BID form included in this document and enclosed in a sealed envelope endorsed on the outside, as indicated in the ADVERTISEMENT FOR BIDS. BID PRICES are to be written, in ink by figures. No BID will be accepted which does not contain a PRICE for each item named in the BID. A conditional or qualified BID will not be accepted. Discrepancies between the multiplication of units of Work and unit prices will be resolved in favor of the unit prices. Discrepancies between the indicated sum of any column of figures and the correct sum thereof will be resolved in favor of the correct sum.
- 7.2. BID forms shall not be separated from this document. If the BID is made by a partnership, it shall contain the names of each partner and shall be signed in the firm name, followed by the signature of a partner or that of a person duly authorized to act for and on behalf of such partnership. If the BID is made by a corporation, it shall be signed with the name of the corporation, followed by the written signature of the qualified officer and the printed designation of the office he holds in the corporation. The address of the BIDDER shall be typed or printed on the BID FORMS.

8. WITHDRAWAL AND CHANGES IN BID

- 8.1. BIDS will be received by the OWNER at the time and place given in the ADVERTISEMENT FOR BIDS. At such time, BIDS will be publicly opened and read.
- 8.2. Change in a BID already delivered will be permitted only if the modification is made prior to the scheduled closing time for the receipt of BIDS. Every modification must be made in writing over the signature of the BIDDER; no other form of procedure will be accepted.

8.3. At any time prior to the scheduled closing time for filing BIDS, a BIDDER may withdraw his BID, either personally or written request. A telephoned request for modification or withdrawal of a BID will not be recognized for this purpose. After the opening of the BIDS, no BIDDER will be allowed to withdraw his BID without the consent of the OWNER for the period of forty-five days after the scheduled time of closing BIDS as stated in the ADVERTISEMENT FOR BIDS. Should there be reasons why the CONTRACT cannot be awarded within the specified period, the time may be extended by mutual agreement between the OWNER and the BIDDER.

9. BID SECURITY

9.1. No BID will be received unless accompanied by a certified check or bank draft as defined in the ADVERTISEMENT FOR BIDS, in an amount not less than five per cent (5%) of the total BID, payable to the OWNER as a guarantee that if the BID is accepted, the BIDDER will execute and file the proposed CONTRACT and BOND within ten (10) days from the date of the award of the CONTRACT. On failure of the successful BIDDER to execute the BOND, he shall forfeit the deposit as agreed as liquidated damages and the acceptance of the BID will be contingent upon the fulfillment of this requirement by the BIDDER.

9.2. The BID security of the three lowest formal BIDDERS will be held until the CONTRACT is executed and approved and then returned to the BIDDERS. All other BID securities submitted will be returned as soon as the BIDS have been compared.

10. PERFORMANCE BOND

10.1. The successful BIDDER at the time of the execution of the CONTRACT must deposit with the OWNER a surety company BOND providing for satisfactory completion of the WORK and the PAYMENT of all debts pertaining to materials or labor used or employed in the execution of the CONTRACT, in an amount equal to the amount of the CONTRACT award. The form of the BOND and surety shall be acceptable to the OWNER.

11. DEFINITION OF AWARD

11.1. The CONTRACT shall be deemed to have been awarded when formal NOTICE OF AWARD has been duly served upon the intended awardee (i.e., to the BIDDER to whom the OWNER contemplates awarding the CONTRACT) by some officer or agent of the OWNER duly authorized to give such notice.

12. NOTICE TO PROCEED

12.1. The NOTICE TO PROCEED shall be issued within ten (10) days of the execution of the AGREEMENT by the OWNER. Should there be reasons why the NOTICE TO PROCEED cannot be issued within such period, the time may be extended by mutual agreement between the OWNER and CONTRACTOR.

13. RIGHT TO REJECT

13.1. The OWNER reserves the right to reject any or all BIDS, to waive any informalities in bidding and select the BID that will best serve the interests of the OWNER.

This page was intentionally left blank.



**EMPIRE SANITARY DISTRICT NO. 3
 SANITARY SEWER RELOCATION
 4TH STREET ROAD/CTH T
 Town of Empire, Fond du Lac County, Wisconsin**

ITEM NUMBER	ITEM DESCRIPTION	ESTIMATED QUANTITY	UNIT	PRICE	COMPUTED TOTAL
1.	8" PVC Sanitary Sewer	73	L.F.	\$ _____	\$ _____
2.	4' Diameter Sanitary Manhole	29	V.F.	\$ _____	\$ _____
3.	Abandon Sanitary Manhole	1	Ea.	\$ _____	\$ _____
4.	Adjust MH-21	1	L.S.	\$ _____	\$ _____
5.	Adjust MH-22	1	L.S.	\$ _____	\$ _____
6.	Adjust MH-28	1	L.S.	\$ _____	\$ _____

BID TOTAL ITEMS 1-6: \$ _____

Starting Date: _____

Calendar Days for Completion: _____

BID

I further certify that no agreement has been entered into to prevent competition for said WORK; that I have carefully examined the site where the WORK is to take place, and the DRAWINGS, SPECIFICATIONS, Form of CONTRACT and BOND, and all CONTRACT DOCUMENTS.

I further agree to enter into the CONTRACT as provided in the CONTRACT DOCUMENTS under all the terms, conditions, and requirements of those DOCUMENTS.

Name of Company submitting

BID: _____

By: _____

Title: _____

Address: _____

Phone: _____

Date: _____

BIDDER'S CERTIFICATE

The undersigned as BIDDER, declares that no person or, persons other than those named herein are interested in the BID:

That this BID is made without collusion with any other person, firm or corporation;

That he has carefully examined the location of the proposed WORK, the proposed FORM OF CONTRACT, and the DRAWINGS and SPECIFICATIONS therein referred to;

That he proposes and agrees, if this BID is accepted, to execute the form of CONTRACT with the OWNER, to provide all necessary equipment, tools and other means of construction and to do all the WORK and furnish all the materials specified in the CONTRACT, including ADDENDA Numbers _____, in the manner and within the time therein described;

That he will take in full payment therefore, the sums set forth in the following BID.

Bidder: _____ By: _____
Authorized Signature

Address: _____ Title: _____

_____ Date: _____

This page was intentionally left blank.

AFFIDAVIT OF BIDDER

STATE OF WISCONSIN)
)SS
COUNTY OF _____)

Pursuant to Section 66.29 (7), Wisconsin Statutes

Name of Authorized Representative

being duly sworn, deposes and says:
That he is the duly authorized representative of

Bidder

and

That the said BIDDER has examined and carefully prepared the BID from the PLANS and SPECIFICATIONS, and has checked the same in detail before submitting said BID to the

Developer

Signed by BIDDER or his authorized representative

Subscribed and sworn to before me

this ____ day of _____, _____

Notary Public

My Commission expires:_____

This page was intentionally left blank.

LIST OF SUBCONTRACTORS

Pursuant to Section 66.0901 (7), Wisconsin Statutes, the BIDDER as part of this BID, submits this full and complete list of all SUBCONTRACTORS and the class of WORK to be performed by each:

<u>Names of Sub-Contractors</u>	<u>Class of Work</u>
_____	_____
_____	_____
_____	_____
_____	_____
_____	_____
_____	_____
_____	_____
_____	_____

I hereby certify that the use of the names of the above SUB-CONTRACTORS was with the knowledge and consent of said SUB-CONTRACTORS.

BIDDER

SUBLETTING OR ASSIGNING OF CONTRACT

If the CONTRACTOR sublets the whole or any part of the WORK to be done under this CONTRACT, he shall not under any circumstances be relieved of his liabilities and obligation. All transactions of the ENGINEER shall be with the CONTRACTOR; SUB-CONTRACTORS shall be recognized only in the capacity of employees or workmen and shall be subject to the same requirements as to character and competence. The CONTRACTOR shall not sublet, assign, transfer, or convey, his right, title or interest therein, or his power to execute such CONTRACT to any person, firm, partnership, or corporation without the written consent of the OWNER.

This page was intentionally left blank.

BID BOND

Accompanying this Proposal is a Certified Check or BID BOND in the amount of

_____ Dollars (\$ _____), payable to the OWNER as a guarantee of good faith, and which, if the CONTRACT is awarded to him, the undersigned agrees to forfeit as liquidated damages to the CITY, in the event of his failure to enter into a CONTRACT or to furnish satisfactory bonds as specified within ten (10) days after notification of the award of this CONTRACT to the undersigned.

Starting and Completion - The undersigned BIDDER, if awarded the CONTRACT, agrees to begin work _____ days after the award of the CONTRACT. The undersigned further agrees to commence work on a date to be specified in a written order from the OWNER which date will not be prior to that established by the calendar days stated above, except by mutual agreement between the undersigned and the OWNER, and agrees to fully complete all the work covered by this

PROPOSAL to the point of final acceptance by the OWNER within _____ consecutive calendar days from and including, the date to start work established in the written order from the OWNER.

DATE _____, _____.

Firm Name

By:

Title

Official Address:

Telephone Number

(Note: BIDDERS should not add any conditions or qualifying statements to this BID as otherwise the bid may be declared irregular as being not responsive to the Advertisement for Bids).

This page was intentionally left blank.

AGREEMENT

THIS AGREEMENT, made on the _____ day of _____, by and between

Town of Empire Sanitary District No. 3,

party of the first part, hereinafter called the OWNER, and

party of the second part, hereinafter called the CONTRACTOR.

WITNESSETH, that the CONTRACTOR and the OWNER, for the considerations hereinafter named, agree as follows:

ARTICLE I - SCOPE OF THE WORK

The CONTRACTOR hereby agrees to furnish all the materials and all of the equipment and labor necessary, and to perform all of the Work shown on the Drawings and described in the Specifications for the project entitled:

Mary Hill Park Sanitary Sewer Relocation, Town of Empire,

all in accordance with the requirements and provisions of the following Documents which are hereby made a part of this Agreement.

- a) Drawings prepared for same by J.E. Arthur and Associates, Inc. numbered **775.005** and dated **December 5, 2025.**
- b) 'General Specifications' as prepared by J. E. Arthur and Associates, Inc. dated **December 5, 2024** with the following Addenda. **n/a**
- c) "Detailed Specifications" as prepared by J.E. Arthur and Associates, Inc. dated **December 5, 2024** with the following Addenda. **n/a**
- d) The "General Conditions of Contract"

ARTICLE II - TIME OF COMPLETION

- a) The Work to be performed under this Contract shall be commenced within ____ calendar days after the date of the Contract.
- b) The Work shall be completed within ____ calendar days after the date of the Contract, with an extension of time for completion equal to any time lost due to causes which could not have been foreseen or which were beyond the control of the CONTRACTOR and which were not the result of his fault or negligence. Extension of Time for Completion" shall also be allowed for any delays in the progress of the Work caused by any act or neglect of the OWNER or of his employees or by other CONTRACTORS employed by the OWNER, or delay due to an act of Government, or by any delay in the furnishing of Drawings and necessary information by the ENGINEER, or by any other cause which in the opinion of the ENGINEER entitles the CONTRACTOR to an extension of time. Strikes and other labor disputes shall be cause for an extension of time for completion.

- c) The CONTRACTOR shall notify the ENGINEER within three (3) days of any occurrence which in the CONTRACTORS opinion entitles him to an extension of time for completion. Such notice shall be in writing and shall be submitted in ample time to permit full investigation and evaluation of the CONTRACTOR'S claim. The ENGINEER shall acknowledge receipt of the CONTRACTOR'S notice within ten (10) days of its receipt Failure to complete the Work within the number of calendar days stated in this Article, including extension granted thereto, shall entitle the OWNER to deduct from the moneys due to the CONTRACTOR as "Liquidated Damages" an amount equal to \$500 for each calendar day of delay in the completion of the Work.

ARTICLE III - THE CONTRACT SUM

- a) The OWNER shall pay to the CONTRACTOR for the performance of the Contract the amounts determined for the total number of each of the following units of Work completed at the unit price stated in this proposal. The number of units contained in this proposal is approximate only, and the final payment shall be made for the actual number of units that are incorporated in or made necessary by the Work covered by the Contract.
- b) Should the number of units of completed Work of any individual item in the proposal vary 15% from the number of units stated in such proposal, either the OWNER or the CONTRACTOR may request a revision of the unit price for the item so affected, and both parties agree that under such conditions an equitable revision of the price shall be made.
- c) Extra Work not included in Article I but authorized after the date of the Contract that cannot be classified as coming under any of the Contract units may be done at mutually agreed upon unit prices, or on a lump sum basis, or under the provisions of Article V "Force Account Work."

ARTICLE IV - PROGRESS PAYMENTS

The OWNER shall make payments on account of the Contract as follows:

- a) On not later than the third day of every month, the CONTRACTOR shall present to the ENGINEER an invoice covering the total quantities under each item of Work that have been completed from the start of the job up to and including the last day of the preceding month; and the value of the Work so completed, determined in accordance with the schedule of unit prices for such items together with such supporting evidence as may be required by the ENGINEER. This invoice shall also include an allowance for the cost of such material required in the permanent Work as has been delivered to the site but not as yet incorporated in the Work.
- b) On not later than the 15th of the month, the OWNER shall after deducting previous payments made, pay to the CONTRACTOR the amount of the invoice, less any retainages permitted by Chapter 66.0901 (9)(a)(b) of the Statutes. The retained amount may be held by the OWNER until the final completion of all the Work under the Contract.
- c) Final payment of all money due on the Contract shall be made within 30 days of completion and acceptance of the Work.

ARTICLE V - FORCE ACCOUNT WORK

If the ENGINEER orders, in writing, the performance of any Work not covered by the Drawings or included in the Specifications, and for which no item in the Contract is provided, and for which no unit price or lump sum basis can be agreed upon, then such extra Work shall be done on a cost-plus percentage basis of payment as follows:

- a) The CONTRACTOR shall be reimbursed for all costs incurred in doing the Work, and shall receive an additional payment of 20% of all such cost to cover his indirect overhead costs, plus 10% of all costs, including indirect overhead, as his fee.

- b) The term "Cost" shall cover all payroll charges for employees and supervision required under the specific order, together with all worker's compensation, Social Security, pension and retirement allowances and social insurance, or other regular payroll charges on same; the cost of all material and supplies required of either temporary or permanent character; rental of all power-driven equipment at agreed-upon rates, together with the cost of fuel and supply charges on same; and any other costs incurred by the CONTRACTOR as a direct result of executing the ORDER, if approved by the ENGINEER.
- c) The Cost of the Work done each day shall be submitted to the ENGINEER in a satisfactory form on the succeeding day and shall be approved by him or adjusted at once.
- d) Monthly payments of all charges for Force Account Work in any one month shall be made in-full on or before the 15th of the succeeding month. Those payments shall include the full amount of the fee earned on the cost of the Work done.

ARTICLE VI— MEASUREMENTS AND FINAL PAYMENT

- a) Upon receipt of written notice that the Work is ready for final measurement and acceptance, the ENGINEER will promptly make such measurement. When he finds the Work functioning as intended under the Contract, he will promptly issue a final certificate, over his own signature, stating that the final measurement has been completed and the entire balance found to be due the CONTRACTOR, including the retained amount, shall be paid to the CONTRACTOR by the OWNER within 30 days after the date of said final certificate.
- b) Before issuance of final certificate, the CONTRACTOR shall submit evidence that all payrolls, material bills, and other indebtedness connected with the Work have been paid, except that in case of disputed indebtedness of liens the CONTRACTOR may submit in lieu of evidence of payment a surety bond satisfactory to the OWNER guaranteeing payment of all such disputed amounts when adjudicated.
- c) The making and acceptance of final payment will constitute a waiver of all claims by the OWNER against the CONTRACTOR, except claims arising from unsettled liens, from defective Work appearing within one (1) year after final payment, or from failure to comply with the Contract Documents or the terms of any special guarantees specified therein; however, it will not constitute a waiver by OWNER of any rights in respect of CONTRACTOR'S continuing obligations under the Contract Documents. It shall also constitute a waiver of all claims by the CONTRACTOR against the OWNER, except those previously made in writing and still unsettled.
- d) If after the Work has been substantially completed, full completion thereof is materially delayed through no fault of the CONTRACTOR, and the ENGINEER so certifies, the OWNER shall, upon certificate of the ENGINEER and without terminating the Contract, make payment of the balance due for that portion of the Work fully completed and accepted. Such payment shall be made under the Terms and Conditions governing final payment, except that it shall not constitute a waiver of claims.

IN WITNESS WHEREOF, the parties hereto have caused this instrument to be executed in three (3) original counterparts, the day and year first written above.

CONTRACTOR

(Seal)

Attest

By:

Date

Title

By:

Date

Title

TOWN OF EMPIRE SAN. DISTRICT NO. 3

(Seal)

Attest

By:

Date

Authorized Signature

By:

Date

Authorized Signature

PERFORMANCE BOND

KNOW ALL MEN BY THESE PRESENTS, That we, _____
_____, as PRINCIPAL, and
_____, as SURETY, are held
and firmly bound unto

hereinafter called the OWNER, in the penal sum of _____ dollars
lawful money of the United States, for the payment of which sum well and truly to be made, we bind
ourselves, our heirs, executors, administrators, successors and assigns, jointly and severally, firmly
by these presents.

The condition of this obligation is such, that whereas the PRINCIPAL has submitted to the OWNER
the attached signed Proposal dated _____, _____, and the attached
signed AGREEMENT based on such Proposal, said Proposal and Agreement being for

Now, Therefore, If the Principal shall not withdraw the said Proposal for the period specified therein
and if, in the event the said Proposal is accepted and the said attached Agreement is executed on
behalf of the OWNER, the Principal shall well and truly perform and fulfill all the undertakings,
covenants, terms and conditions of the Proposal and Agreement as accepted, and any and all duly
authorized modifications of the said Agreement that may hereafter be made, shall promptly make
payment to all persons supplying the Principal with labor and materials in the prosecution of the
work provided for in said Agreement and any such authorized extension of modification thereof,
then, this obligation to be void: otherwise to remain in full force and virtue.

And the said Surety, for value received hereby stipulates and agrees that no change, extension of
time, alteration or addition to the terms of the Agreement or to the WORK to be performed
thereunder or the SPECIFICATIONS accompanying the same shall in any way affect its obligations
on this BOND, and it does hereby waive notice of any such change, extension of time, alteration or
addition to the terms of the Agreement or to the WORK or to the SPECIFICATIONS.

IN WITNESS WHEREOF, the above-bounden parties have executed this instrument, in original
counterpart, under their several seals this _____ day of _____, the
name and corporate seal of each corporate party being hereto affixed and these presents duly
signed by its undersigned representatives pursuant to authority of its governing body.

In Presence of:

_____ Date _____ Individual Principal _____ (Seal)

_____ Business Address _____

_____ Date _____ Individual Principal _____ (Seal)

_____ Business Address _____

_____ Date _____ Corporate Principal _____ (Seal)

_____ Business Address _____

ATTEST:

_____ Date _____ By: _____ Affix Corporate Seal

Approved: _____

_____ Title

NOTE: The bond must be approved and the approval dated in every case; refer to Section 779.14 Wisconsin Statutes.

CERTIFICATE OF INSURANCE

_____ Company

_____ Wisconsin

Location of work _____

Reference - Project No. _____

Date _____, _____

The undersigned insurers by their duly authorized agents or attorneys in fact hereby severally certify that:

1. The insurances referred to opposite their names respectively are now in effect, which name as the assured, the CONTRACTOR of the AGREEMENT, to which this certificate is attached.
2. That such insurances will not be cancelled in whole or in part without first giving the principal ten days advance notice, prior to such cancellation; and
3. That such insurances, as are herein designated include all of the insuring provisions required by the AGREEMENT of the CONTRACTOR so as to fully indemnify the principal and the CONTRACTOR and/or his SUBCONTRACTORS against any and all claims and expenses, against either or so many of them, resulting from the performance of the CONTRACT.

In witness whereof we have hereunto set our hands with full power-to do so (Power of Attorney attached) on the dates designated.

Type of Insurances:	Policy No.	Date of Policy	Amount	Insurers
Workmen's Compensation	_____	_____	_____	_____
Public Liability--Bodily Injuries and Property Damage (Other than From Automotive Equipment)	_____	_____	_____	_____
Public Liability--Bodily Injuries and Property Damages (From Automotive Equipment)	_____	_____	_____	_____
Fire and Extended Coverage	_____	_____	_____	_____

The CONTRACTOR hereby certifies that he has heretofore complied, and will during the progress of the WORK comply with the Wisconsin Unemployment Insurance Act and will hold the Company harmless from any liability for benefits under such Act or Acts by reason of discontinuance by the CONTRACTOR of the employment of any person engaged by the CONTRACTOR upon the WORK. The CONTRACTOR also hereby certifies that he will during the progress of the WORK comply with the Federal Social Security Act and will hold the Company harmless from any Social Security payments and provisions required by such Act respecting his or his SUBCONTRACTORS' employees.

Date: _____

CONTRACTOR

NOTICE OF AWARD

To: _____

Project Description: 4TH STREET ROAD/CTH T SEWER RELOCATION
TOWN OF EMPIRE

The OWNER has considered the BID submitted by you for the above described WORK in response to its ADVERTISEMENT FOR BIDS dated **December 5, 2024.**

You are hereby notified that your BID for the above PROJECT in the amount of _____ has been accepted by the OWNER and that the OWNER has awarded the CONTRACT to you.

The CONTRACTS are being prepared and will be forwarded to you when completed. You are required by the INFORMATION FOR BIDDERS to execute the AGREEMENT and-furnish the required CONTRACTOR'S PERFORMANCE BOND and CERTIFICATES OF INSURANCE within ten (10) calendar days from the date of this Notice to you.

You are required to return an acknowledged copy of this NOTICE OF AWARD to the OWNER and the ENGINEER.

Dated this _____ day of _____.

Eric R. Otte

Engineer

By: Eric R. Otte

Title: President

ACCEPTANCE OF NOTICE

Receipt of the above NOTICE OF AWARD is hereby acknowledged.

By:

This the _____ day of _____,

By _____

Title _____

This page was intentionally left blank.

NOTICE TO PROCEED

To: _____

Date: _____
Project: _____
SANITARY SEWER RELOCATION
4TH STREET ROAD
TOWN OF EMPIRE

You are hereby notified to commence WORK in accordance with the AGREEMENT dated _____ on or before _____ and you are to complete the WORK within ___ consecutive calendar days thereafter. The date of completion of all WORK is therefore _____.

Eric R. Otte

Engineer
By: Eric R. Otte

Title: President

ACCEPTANCE OF NOTICE

Receipt of the above NOTICE TO PROCEED is hereby acknowledged.

by _____
this _____ the day
of _____, _____

By _____
Title _____

This page was intentionally left blank.

CHANGE ORDER

CHANGE ORDER NO. _____ DATE _____

PROJECT NO. _____ PROJECT NAME _____

OWNER _____

CONTRACTOR _____

THE FOLLOWING CHANGES ARE HEREBY MADE TO THE CONTRACT DOCUMENTS:

TOTAL AMOUNT (ADDED, DEDUCTED) THIS CHANGE ORDER \$ _____

ORIGINAL CONTRACT AMOUNT \$ _____

CURRENT CONTRACT AMOUNT ADJUSTED BY PREVIOUS CHANGE ORDER \$ _____

ADDITIONS THIS CHANGE ORDER \$ _____

DEDUCTIONS THIS CHANGE ORDER \$ _____

NEW CONTRACT AMOUNT INCLUDING THIS CHANGE ORDER \$ _____

THE CONTRACT TIME WILL BE (INCREASED, DECREASED) BY _____ CALENDAR
DAYS

THE DATE FOR COMPLETION OF ALL WORK WILL BE

APPROVED _____
OWNER

APPROVED _____
OWNER

APPROVED _____
CONTRACTOR

APPROVED _____
J.E. ARTHUR AND ASSOCIATES, INC.

This page was intentionally left blank.

This document has important legal consequences; consultation with an attorney is encouraged with respect to its use or modification. This document should be adapted to the particular circumstances of the contemplated Project and the Controlling Law.

STANDARD
GENERAL CONDITIONS
OF THE
CONSTRUCTION CONTRACT

Prepared by

ENGINEERS JOINT CONTRACT DOCUMENTS COMMITTEE

and

Issued and Published Jointly By



PROFESSIONAL ENGINEERS IN PRIVATE PRACTICE
a practice division of the
NATIONAL SOCIETY OF PROFESSIONAL ENGINEERS

AMERICAN COUNCIL OF ENGINEERING COMPANIES

AMERICAN SOCIETY OF CIVIL ENGINEERS

This document has been approved and endorsed by



The Associated General Contractors of America

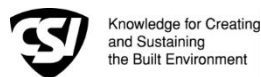

Construction Specifications Institute

Copyright ©2002

National Society of Professional Engineers
1420 King Street, Alexandria, VA 22314

American Council of Engineering Companies
1015 15th Street, N.W., Washington, DC 20005

American Society of Civil Engineers
1801 Alexander Bell Drive, Reston, VA 20191-4400

These General Conditions have been prepared for use with the Suggested Forms of Agreement Between Owner and Contractor Nos. C-520 or C-525 (2002 Editions). Their provisions are interrelated and a change in one may necessitate a change in the other. Comments concerning their usage are contained in the EJCDC Construction Documents, General and Instructions (No. C-001) (2002 Edition). For guidance in the preparation of Supplementary Conditions, see Guide to the Preparation of Supplementary Conditions (No. C-800) (2002 Edition).

TABLE OF CONTENTS

	<u>Page</u>
ARTICLE 1 - DEFINITIONS AND TERMINOLOGY	6
1.01 <i>Defined Terms</i>	6
1.02 <i>Terminology</i>	8
ARTICLE 2 - PRELIMINARY MATTERS	9
2.01 <i>Delivery of Bonds and Evidence of Insurance</i>	9
2.02 <i>Copies of Documents</i>	9
2.03 <i>Commencement of Contract Times; Notice to Proceed</i>	9
2.04 <i>Starting the Work</i>	9
2.05 <i>Before Starting Construction</i>	9
2.06 <i>Preconstruction Conference</i>	9
2.07 <i>Initial Acceptance of Schedules</i>	9
ARTICLE 3 - CONTRACT DOCUMENTS: INTENT, AMENDING, REUSE	10
3.01 <i>Intent</i>	10
3.02 <i>Reference Standards</i>	10
3.03 <i>Reporting and Resolving Discrepancies</i>	10
3.04 <i>Amending and Supplementing Contract Documents</i>	11
3.05 <i>Reuse of Documents</i>	11
3.06 <i>Electronic Data</i>	11
ARTICLE 4 - AVAILABILITY OF LANDS; SUBSURFACE AND PHYSICAL CONDITIONS; HAZARDOUS ENVIRONMENTAL CONDITIONS; REFERENCE POINTS	11
4.01 <i>Availability of Lands</i>	11
4.02 <i>Subsurface and Physical Conditions</i>	12
4.03 <i>Differing Subsurface or Physical Conditions</i>	12
4.04 <i>Underground Facilities</i>	13
4.05 <i>Reference Points</i>	13
4.06 <i>Hazardous Environmental Condition at Site</i>	13
ARTICLE 5 - BONDS AND INSURANCE	14
5.01 <i>Performance, Payment, and Other Bonds</i>	14
5.02 <i>Licensed Sureties and Insurers</i>	15
5.03 <i>Certificates of Insurance</i>	15
5.04 <i>Contractor's Liability Insurance</i>	15
5.05 <i>Owner's Liability Insurance</i>	16
5.06 <i>Property Insurance</i>	16
5.07 <i>Waiver of Rights</i>	17
5.08 <i>Receipt and Application of Insurance Proceeds</i>	17
5.09 <i>Acceptance of Bonds and Insurance; Option to Replace</i>	17
5.10 <i>Partial Utilization, Acknowledgment of Property Insurer</i>	18
ARTICLE 6 - CONTRACTOR'S RESPONSIBILITIES	18
6.01 <i>Supervision and Superintendence</i>	18
6.02 <i>Labor; Working Hours</i>	18
6.03 <i>Services, Materials, and Equipment</i>	18
6.04 <i>Progress Schedule</i>	18
6.05 <i>Substitutes and "Or-Equals"</i>	19
6.06 <i>Concerning Subcontractors, Suppliers, and Others</i>	20
6.07 <i>Patent Fees and Royalties</i>	21
6.08 <i>Permits</i>	21
6.09 <i>Laws and Regulations</i>	21
6.10 <i>Taxes</i>	22
6.11 <i>Use of Site and Other Areas</i>	22
6.12 <i>Record Documents</i>	22
6.13 <i>Safety and Protection</i>	22
6.14 <i>Safety Representative</i>	23
6.15 <i>Hazard Communication Programs</i>	23
6.16 <i>Emergencies</i>	23

6.17	<i>Shop Drawings and Samples</i>	23
6.18	<i>Continuing the Work</i>	24
6.19	<i>Contractor's General Warranty and Guarantee</i>	24
6.20	<i>Indemnification</i>	24
6.21	<i>Delegation of Professional Design Services</i>	25
ARTICLE 7 - OTHER WORK AT THE SITE		25
7.01	<i>Related Work at Site</i>	25
7.02	<i>Coordination</i>	26
7.03	<i>Legal Relationships</i>	26
ARTICLE 8 - OWNER'S RESPONSIBILITIES		26
8.01	<i>Communications to Contractor</i>	26
8.02	<i>Replacement of Engineer</i>	26
8.03	<i>Furnish Data</i>	26
8.04	<i>Pay When Due</i>	26
8.05	<i>Lands and Easements; Reports and Tests</i>	26
8.06	<i>Insurance</i>	26
8.07	<i>Change Orders</i>	26
8.08	<i>Inspections, Tests, and Approvals</i>	26
8.09	<i>Limitations on Owner's Responsibilities</i>	27
8.10	<i>Undisclosed Hazardous Environmental Condition</i>	27
8.11	<i>Evidence of Financial Arrangements</i>	27
ARTICLE 9 - ENGINEER'S STATUS DURING CONSTRUCTION		27
9.01	<i>Owner's Representative</i>	27
9.02	<i>Visits to Site</i>	27
9.03	<i>Project Representative</i>	27
9.04	<i>Authorized Variations in Work</i>	27
9.05	<i>Rejecting Defective Work</i>	27
9.06	<i>Shop Drawings, Change Orders and Payments</i>	28
9.07	<i>Determinations for Unit Price Work</i>	28
9.08	<i>Decisions on Requirements of Contract Documents and Acceptability of Work</i>	28
9.09	<i>Limitations on Engineer's Authority and Responsibilities</i>	28
ARTICLE 10 - CHANGES IN THE WORK; CLAIMS		28
10.01	<i>Authorized Changes in the Work</i>	28
10.02	<i>Unauthorized Changes in the Work</i>	29
10.03	<i>Execution of Change Orders</i>	29
10.04	<i>Notification to Surety</i>	29
10.05	<i>Claims</i>	29
ARTICLE 11 - COST OF THE WORK; ALLOWANCES; UNIT PRICE WORK		30
11.01	<i>Cost of the Work</i>	30
11.02	<i>Allowances</i>	31
11.03	<i>Unit Price Work</i>	31
ARTICLE 12 - CHANGE OF CONTRACT PRICE; CHANGE OF CONTRACT TIMES		32
12.01	<i>Change of Contract Price</i>	32
12.02	<i>Change of Contract Times</i>	33
12.03	<i>Delays</i>	33
ARTICLE 13 - TESTS AND INSPECTIONS; CORRECTION, REMOVAL OR ACCEPTANCE OF DEFECTIVE WORK		33
13.01	<i>Notice of Defects</i>	33
13.02	<i>Access to Work</i>	33
13.03	<i>Tests and Inspections</i>	33
13.04	<i>Uncovering Work</i>	34
13.05	<i>Owner May Stop the Work</i>	34
13.06	<i>Correction or Removal of Defective Work</i>	34
13.07	<i>Correction Period</i>	34
13.08	<i>Acceptance of Defective Work</i>	35
13.09	<i>Owner May Correct Defective Work</i>	35
ARTICLE 14 - PAYMENTS TO CONTRACTOR AND COMPLETION		36
14.01	<i>Schedule of Values</i>	36
14.02	<i>Progress Payments</i>	36
14.03	<i>Contractor's Warranty of Title</i>	37
14.04	<i>Substantial Completion</i>	37
14.05	<i>Partial Utilization</i>	38

14.06	<i>Final Inspection</i>	38
14.07	<i>Final Payment</i>	38
14.08	<i>Final Completion Delayed</i>	39
14.09	<i>Waiver of Claims</i>	39
ARTICLE 15 - SUSPENSION OF WORK AND TERMINATION		39
15.01	<i>Owner May Suspend Work</i>	39
15.02	<i>Owner May Terminate for Cause</i>	39
15.03	<i>Owner May Terminate For Convenience</i>	40
15.04	<i>Contractor May Stop Work or Terminate</i>	40
ARTICLE 16 - DISPUTE RESOLUTION		41
16.01	<i>Methods and Procedures</i>	41
ARTICLE 17 - MISCELLANEOUS		41
17.01	<i>Giving Notice</i>	41
17.02	<i>Computation of Times</i>	41
17.03	<i>Cumulative Remedies</i>	41
17.04	<i>Survival of Obligations</i>	41
17.05	<i>Controlling Law</i>	41
17.06	<i>Headings</i>	41

GENERAL CONDITIONS

ARTICLE 1 - DEFINITIONS AND TERMINOLOGY

1.01 *Defined Terms*

A. Wherever used in the Bidding Requirements or Contract Documents and printed with initial capital letters, the terms listed below will have the meanings indicated which are applicable to both the singular and plural thereof. In addition to terms specifically defined, terms with initial capital letters in the Contract Documents include references to identified articles and paragraphs, and the titles of other documents or forms.

1. *Addenda*--Written or graphic instruments issued prior to the opening of Bids which clarify, correct, or change the Bidding Requirements or the proposed Contract Documents.

2. *Agreement*--The written instrument which is evidence of the agreement between Owner and Contractor covering the Work.

3. *Application for Payment*--The form acceptable to Engineer which is to be used by Contractor during the course of the Work in requesting progress or final payments and which is to be accompanied by such supporting documentation as is required by the Contract Documents.

4. *Asbestos*--Any material that contains more than one percent asbestos and is friable or is releasing asbestos fibers into the air above current action levels established by the United States Occupational Safety and Health Administration.

5. *Bid*--The offer or proposal of a Bidder submitted on the prescribed form setting forth the prices for the Work to be performed.

6. *Bidder*--The individual or entity who submits a Bid directly to Owner.

7. *Bidding Documents*--The Bidding Requirements and the proposed Contract Documents (including all Addenda).

8. *Bidding Requirements*--The Advertisement or Invitation to Bid, Instructions to Bidders, bid security of acceptable form, if any, and the Bid Form with any supplements.

9. *Change Order*--A document recommended by Engineer which is signed by Contractor and Owner and authorizes an addition, deletion, or revision in the Work or an adjustment in the Contract Price or the Contract Times, issued on or after the Effective Date of the Agreement.

10. *Claim*--A demand or assertion by Owner or Contractor seeking an adjustment of Contract Price or Contract Times, or both, or other relief with respect to the terms of the Contract. A demand for money or services by a third party is not a Claim.

11. *Contract*--The entire and integrated written agreement between the Owner and Contractor concerning the Work. The Contract supersedes prior negotiations, representations, or agreements, whether written or oral.

12. *Contract Documents*-- Those items so designated in the Agreement. Only printed or hard copies of the items listed in the Agreement are Contract Documents. Approved Shop Drawings, other Contractor's submittals, and the reports and drawings of subsurface and physical conditions are not Contract Documents.

13. *Contract Price*--The moneys payable by Owner to Contractor for completion of the Work in accordance with the Contract Documents as stated in the Agreement (subject to the provisions of Paragraph 11.03 in the case of Unit Price Work).

14. *Contract Times*--The number of days or the dates stated in the Agreement to: (i) achieve Milestones, if any, (ii) achieve Substantial Completion; and (iii) complete the Work so that it is ready for final payment as evidenced by Engineer's written recommendation of final payment.

15. *Contractor*--The individual or entity with whom Owner has entered into the Agreement.

16. *Cost of the Work*--See Paragraph 11.01.A for definition.

17. *Drawings*--That part of the Contract Documents prepared or approved by Engineer which graphically shows the scope, extent, and character of the Work to be performed by Contractor. Shop Drawings and other Contractor submittals are not Drawings as so defined.

18. *Effective Date of the Agreement*--The date indicated in the Agreement on which it becomes effective, but if no such date is indicated, it means the date on which the Agreement is signed and delivered by the last of the two parties to sign and deliver.

19. *Engineer*--The individual or entity named as such in the Agreement.

20. *Field Order*--A written order issued by Engineer which requires minor changes in the Work but which does not involve a change in the Contract Price or the Contract Times.

21. *General Requirements*--Sections of Division 1 of the Specifications. The General Requirements pertain to all sections of the Specifications.

22. *Hazardous Environmental Condition*--The presence at the Site of Asbestos, PCBs, Petroleum, Hazardous Waste, or Radioactive Material in such quantities or circumstances that may present a substantial danger to persons or property exposed thereto in connection with the Work.

23. *Hazardous Waste*--The term Hazardous Waste shall have the meaning provided in Section 1004 of the Solid Waste Disposal Act (42 USC Section 6903) as amended from time to time.

24. *Laws and Regulations; Laws or Regulations*--Any and all applicable laws, rules, regulations, ordinances, codes, and orders of any and all governmental bodies, agencies, authorities, and courts having jurisdiction.

25. *Liens*--Charges, security interests, or encumbrances upon Project funds, real property, or personal property.

26. *Milestone*--A principal event specified in the Contract Documents relating to an intermediate completion date or time prior to Substantial Completion of all the Work.

27. *Notice of Award*--The written notice by Owner to the Successful Bidder stating that upon timely compliance by the Successful Bidder with the conditions precedent listed therein, Owner will sign and deliver the Agreement.

28. *Notice to Proceed*--A written notice given by Owner to Contractor fixing the date on which the Contract Times will commence to run and on which Contractor shall start to perform the Work under the Contract Documents.

29. *Owner*--The individual or entity with whom Contractor has entered into the Agreement and for whom the Work is to be performed.

30. *PCBs*--Polychlorinated biphenyls.

31. *Petroleum*--Petroleum, including crude oil or any fraction thereof which is liquid at standard conditions of temperature and pressure (60 degrees Fahrenheit and 14.7 pounds per square inch absolute), such as oil, petroleum, fuel oil, oil sludge, oil refuse, gasoline, kerosene, and oil mixed with other non-Hazardous Waste and crude oils.

32. *Progress Schedule*--A schedule, prepared and maintained by Contractor, describing the sequence and duration of the activities comprising the Contractor's plan to accomplish the Work within the Contract Times.

33. *Project*--The total construction of which the Work to be performed under the Contract Documents may be the whole, or a part.

34. *Project Manual*--The bound documentary information prepared for bidding and constructing the Work. A listing of the contents of the Project Manual, which may be bound in one or more volumes, is contained in the table(s) of contents.

35. *Radioactive Material*--Source, special nuclear, or byproduct material as defined by the Atomic Energy Act of 1954 (42 USC Section 2011 et seq.) as amended from time to time.

36. *Related Entity* -- An officer, director, partner, employee, agent, consultant, or subcontractor.

37. *Resident Project Representative*--The authorized representative of Engineer who may be assigned to the Site or any part thereof.

38. *Samples*--Physical examples of materials, equipment, or workmanship that are representative of some portion of the Work and which establish the standards by which such portion of the Work will be judged.

39. *Schedule of Submittals*--A schedule, prepared and maintained by Contractor, of required submittals and the time requirements to support scheduled performance of related construction activities.

40. *Schedule of Values*--A schedule, prepared and maintained by Contractor, allocating portions of the Contract Price to various portions of the Work and used as the basis for reviewing Contractor's Applications for Payment.

41. *Shop Drawings*--All drawings, diagrams, illustrations, schedules, and other data or information which are specifically prepared or assembled by or for Contractor and submitted by Contractor to illustrate some portion of the Work.

42. *Site*--Lands or areas indicated in the Contract Documents as being furnished by Owner upon which the Work is to be performed, including rights-of-way and easements for access thereto, and such other lands furnished by Owner which are designated for the use of Contractor.

43. *Specifications*--That part of the Contract Documents consisting of written requirements for materials, equipment, systems, standards and workmanship as applied to the Work, and certain

administrative requirements and procedural matters applicable thereto.

44. *Subcontractor*--An individual or entity having a direct contract with Contractor or with any other Subcontractor for the performance of a part of the Work at the Site.

45. *Substantial Completion*--The time at which the Work (or a specified part thereof) has progressed to the point where, in the opinion of Engineer, the Work (or a specified part thereof) is sufficiently complete, in accordance with the Contract Documents, so that the Work (or a specified part thereof) can be utilized for the purposes for which it is intended. The terms "substantially complete" and "substantially completed" as applied to all or part of the Work refer to Substantial Completion thereof.

46. *Successful Bidder*--The Bidder submitting a responsive Bid to whom Owner makes an award.

47. *Supplementary Conditions*--That part of the Contract Documents which amends or supplements these General Conditions.

48. *Supplier*--A manufacturer, fabricator, supplier, distributor, materialman, or vendor having a direct contract with Contractor or with any Subcontractor to furnish materials or equipment to be incorporated in the Work by Contractor or any Subcontractor.

49. *Underground Facilities*--All underground pipelines, conduits, ducts, cables, wires, manholes, vaults, tanks, tunnels, or other such facilities or attachments, and any encasements containing such facilities, including those that convey electricity, gases, steam, liquid petroleum products, telephone or other communications, cable television, water, wastewater, storm water, other liquids or chemicals, or traffic or other control systems.

50. *Unit Price Work*--Work to be paid for on the basis of unit prices.

51. *Work*--The entire construction or the various separately identifiable parts thereof required to be provided under the Contract Documents. Work includes and is the result of performing or providing all labor, services, and documentation necessary to produce such construction, and furnishing, installing, and incorporating all materials and equipment into such construction, all as required by the Contract Documents.

52. *Work Change Directive*--A written statement to Contractor issued on or after the Effective Date of the Agreement and signed by Owner and recommended by Engineer ordering an addition, deletion, or revision in the Work, or responding to differing or unforeseen subsurface or physical conditions under which the Work is to be performed or to emergencies. A Work Change Directive will not change the Contract Price or the Contract Times

but is evidence that the parties expect that the change ordered or documented by a Work Change Directive will be incorporated in a subsequently issued Change Order following negotiations by the parties as to its effect, if any, on the Contract Price or Contract Times.

1.02 Terminology

A. The following words or terms are not defined but, when used in the Bidding Requirements or Contract Documents, have the following meaning.

B. Intent of Certain Terms or Adjectives

1. The Contract Documents include the terms "as allowed," "as approved," "as ordered," "as directed" or terms of like effect or import to authorize an exercise of professional judgment by Engineer. In addition, the adjectives "reasonable," "suitable," "acceptable," "proper," "satisfactory," or adjectives of like effect or import are used to describe an action or determination of Engineer as to the Work. It is intended that such exercise of professional judgment, action or determination will be solely to evaluate, in general, the Work for compliance with the requirements of and information in the Contract Documents and conformance with the design concept of the completed Project as a functioning whole as shown or indicated in the Contract Documents (unless there is a specific statement indicating otherwise). The use of any such term or adjective is not intended to and shall not be effective to assign to Engineer any duty or authority to supervise or direct the performance of the Work or any duty or authority to undertake responsibility contrary to the provisions of Paragraph 9.09 or any other provision of the Contract Documents.

C. Day

1. The word "day" means a calendar day of 24 hours measured from midnight to the next midnight.

D. Defective

1. The word "defective," when modifying the word "Work," refers to Work that is unsatisfactory, faulty, or deficient in that it:

- a. does not conform to the Contract Documents, or
- b. does not meet the requirements of any applicable inspection, reference standard, test, or approval referred to in the Contract Documents, or
- c. has been damaged prior to Engineer's - recommendation of final payment (unless responsibility for the protection thereof has been assumed by Owner at Substantial Completion in accordance with Paragraph 14.04 or 14.05).

E. Furnish, Install, Perform, Provide

1. The word “furnish,” when used in connection with services, materials, or equipment, shall mean to supply and deliver said services, materials, or equipment to the Site (or some other specified location) ready for use or installation and in usable or operable condition.

2. The word “install,” when used in connection with services, materials, or equipment, shall mean to put into use or place in final position said services, materials, or equipment complete and ready for intended use.

3. The words “perform” or “provide,” when used in connection with services, materials, or equipment, shall mean to furnish and install said services, materials, or equipment complete and ready for intended use.

4. When “furnish,” “install,” “perform,” or “provide” is not used in connection with services, materials, or equipment in a context clearly requiring an obligation of Contractor, “provide” is implied.

F. Unless stated otherwise in the Contract Documents, words or phrases which have a well-known technical or construction industry or trade meaning are used in the Contract Documents in accordance with such recognized meaning.

ARTICLE 2 - PRELIMINARY MATTERS

2.01 *Delivery of Bonds and Evidence of Insurance*

A. When Contractor delivers the executed counterparts of the Agreement to Owner, Contractor shall also deliver to Owner such bonds as Contractor may be required to furnish.

B. *Evidence of Insurance:* Before any Work at the Site is started, Contractor and Owner shall each deliver to the other, with copies to each additional insured identified in the Supplementary Conditions, certificates of insurance (and other evidence of insurance which either of them or any additional insured may reasonably request) which Contractor and Owner respectively are required to purchase and maintain in accordance with Article 5.

2.02 *Copies of Documents*

A. Owner shall furnish to Contractor up to ten printed or hard copies of the Drawings and Project Manual. Additional copies will be furnished upon request at the cost of reproduction.

2.03 *Commencement of Contract Times; Notice to Proceed*

A. The Contract Times will commence to run on the thirtieth day after the Effective Date of the Agreement

or, if a Notice to Proceed is given, on the day indicated in the Notice to Proceed. A Notice to Proceed may be given at any time within 30 days after the Effective Date of the Agreement. In no event will the Contract Times commence to run later than the sixtieth day after the day of Bid opening or the thirtieth day after the Effective Date of the Agreement, whichever date is earlier.

2.04 *Starting the Work*

A. Contractor shall start to perform the Work on the date when the Contract Times commence to run. No Work shall be done at the Site prior to the date on which the Contract Times commence to run.

2.05 *Before Starting Construction*

A. *Preliminary Schedules:* Within 10 days after the Effective Date of the Agreement (unless otherwise specified in the General Requirements), Contractor shall submit to Engineer for timely review:

1. a preliminary Progress Schedule; indicating the times (numbers of days or dates) for starting and completing the various stages of the Work, including any Milestones specified in the Contract Documents;

2. a preliminary Schedule of Submittals; and

3. a preliminary Schedule of Values for all of the Work which includes quantities and prices of items which when added together equal the Contract Price and subdivides the Work into component parts in sufficient detail to serve as the basis for progress payments during performance of the Work. Such prices will include an appropriate amount of overhead and profit applicable to each item of Work.

2.06 *Preconstruction Conference*

A. Before any Work at the Site is started, a conference attended by Owner, Contractor, Engineer, and others as appropriate will be held to establish a working understanding among the parties as to the Work and to discuss the schedules referred to in Paragraph 2.05.A, procedures for handling Shop Drawings and other submittals, processing Applications for Payment, and maintaining required records.

2.07 *Initial Acceptance of Schedules*

A. At least 10 days before submission of the first Application for Payment a conference attended by Contractor, Engineer, and others as appropriate will be held to review for acceptability to Engineer as provided below the schedules submitted in accordance with Paragraph 2.05.A. Contractor shall have an additional 10 days to make corrections and adjustments and to complete and resubmit the schedules. No progress payment shall be made to Contractor until acceptable schedules are submitted to Engineer.

1. The Progress Schedule will be acceptable to Engineer if it provides an orderly progression of the Work to completion within the Contract Times. Such acceptance will not impose on Engineer responsibility for the Progress Schedule, for sequencing, scheduling, or progress of the Work nor interfere with or relieve Contractor from Contractor's full responsibility therefor.

2. Contractor's Schedule of Submittals will be acceptable to Engineer if it provides a workable arrangement for reviewing and processing the required submittals.

3. Contractor's Schedule of Values will be acceptable to Engineer as to form and substance if it provides a reasonable allocation of the Contract Price to component parts of the Work.

ARTICLE 3 - CONTRACT DOCUMENTS: INTENT, AMENDING, REUSE

3.01 *Intent*

A. The Contract Documents are complementary; what is required by one is as binding as if required by all.

B. It is the intent of the Contract Documents to describe a functionally complete Project (or part thereof) to be constructed in accordance with the Contract Documents. Any labor, documentation, services, materials, or equipment that may reasonably be inferred from the Contract Documents or from prevailing custom or trade usage as being required to produce the intended result will be provided whether or not specifically called for at no additional cost to Owner.

C. Clarifications and interpretations of the Contract Documents shall be issued by Engineer as provided in Article 9.

3.02 *Reference Standards*

A. Standards, Specifications, Codes, Laws, and Regulations

1. Reference to standards, specifications, manuals, or codes of any technical society, organization, or association, or to Laws or Regulations, whether such reference be specific or by implication, shall mean the standard, specification, manual, code, or Laws or Regulations in effect at the time of opening of Bids (or on the Effective Date of the Agreement if there were no Bids), except as may be otherwise specifically stated in the Contract Documents.

2. No provision of any such standard, specification, manual or code, or any instruction of a Supplier shall be effective to change the duties or

responsibilities of Owner, Contractor, or Engineer, or any of their subcontractors, consultants, agents, or employees from those set forth in the Contract Documents. No such provision or instruction shall be effective to assign to Owner, or Engineer, or any of, their Related Entities, any duty or authority to supervise or direct the performance of the Work or any duty or authority to undertake responsibility inconsistent with the provisions of the Contract Documents.

3.03 *Reporting and Resolving Discrepancies*

A. Reporting Discrepancies

1. *Contractor's Review of Contract Documents Before Starting Work:* Before undertaking each part of the Work, Contractor shall carefully study and compare the Contract Documents and check and verify pertinent figures therein and all applicable field measurements. Contractor shall promptly report in writing to Engineer any conflict, error, ambiguity, or discrepancy which Contractor may discover and shall obtain a written interpretation or clarification from Engineer before proceeding with any Work affected thereby.

2. *Contractor's Review of Contract Documents During Performance of Work:* If, during the performance of the Work, Contractor discovers any conflict, error, ambiguity, or discrepancy within the Contract Documents or between the Contract Documents and any provision of any Law or Regulation applicable to the performance of the Work or of any standard, specification, manual or code, or of any instruction of any Supplier, Contractor shall promptly report it to Engineer in writing. Contractor shall not proceed with the Work affected thereby (except in an emergency as required by Paragraph 6.16.A) until an amendment or supplement to the Contract Documents has been issued by one of the methods indicated in Paragraph 3.04.

3. Contractor shall not be liable to Owner or Engineer for failure to report any conflict, error, ambiguity, or discrepancy in the Contract Documents unless Contractor knew or reasonably should have known thereof.

B. Resolving Discrepancies

1. Except as may be otherwise specifically stated in the Contract Documents, the provisions of the Contract Documents shall take precedence in resolving any conflict, error, ambiguity, or discrepancy between the provisions of the Contract Documents and:

a. the provisions of any standard, specification, manual, code, or instruction (whether or not specifically incorporated by reference in the Contract Documents); or

b. the provisions of any Laws or Regulations applicable to the performance of the Work

(unless such an interpretation of the provisions of the Contract Documents would result in violation of such Law or Regulation).

3.04 *Amending and Supplementing Contract Documents*

A. The Contract Documents may be amended to provide for additions, deletions, and revisions in the Work or to modify the terms and conditions thereof by either a Change Order or a Work Change Directive.

B. The requirements of the Contract Documents may be supplemented, and minor variations and deviations in the Work may be authorized, by one or more of the following ways:

1. A Field Order;

2. Engineer's approval of a Shop Drawing or Sample; (Subject to the provisions of Paragraph 6.17.D.3); or

3. Engineer's written interpretation or clarification.

3.05 *Reuse of Documents*

A. Contractor and any Subcontractor or Supplier or other individual or entity performing or furnishing all of the Work under a direct or indirect contract with Contractor, shall not:

1. have or acquire any title to or ownership rights in any of the Drawings, Specifications, or other documents (or copies of any thereof) prepared by or bearing the seal of Engineer or Engineer's consultants, including electronic media editions; or

2. reuse any of such Drawings, Specifications, other documents, or copies thereof on extensions of the Project or any other project without written consent of Owner and Engineer and specific written verification or adaption by Engineer.

B. The prohibition of this Paragraph 3.05 will survive final payment, or termination of the Contract. Nothing herein shall preclude Contractor from retaining copies of the Contract Documents for record purposes.

3.06 *Electronic Data*

A. Copies of data furnished by Owner or Engineer to Contractor or Contractor to Owner or Engineer that may be relied upon are limited to the printed copies (also known as hard copies). Files in electronic media format of text, data, graphics, or other types are furnished only for the convenience of the receiving party. Any conclusion or information obtained or derived from such electronic files will be at the user's

sole risk. If there is a discrepancy between the electronic files and the hard copies, the hard copies govern.

B. Because data stored in electronic media format can deteriorate or be modified inadvertently or otherwise without authorization of the data's creator, the party receiving electronic files agrees that it will perform acceptance tests or procedures within 60 days, after which the receiving party shall be deemed to have accepted the data thus transferred. Any errors detected within the 60-day acceptance period will be corrected by the transferring party..

C. When transferring documents in electronic media format, the transferring party makes no representations as to long term compatibility, usability, or readability of documents resulting from the use of software application packages, operating systems, or computer hardware differing from those used by the data's creator.

ARTICLE 4 - AVAILABILITY OF LANDS; SUBSURFACE AND PHYSICAL CONDITIONS; HAZARDOUS ENVIRONMENTAL CONDITIONS; REFERENCE POINTS

4.01 *Availability of Lands*

A. Owner shall furnish the Site. Owner shall notify Contractor of any encumbrances or restrictions not of general application but specifically related to use of the Site with which Contractor must comply in performing the Work. Owner will obtain in a timely manner and pay for easements for permanent structures or permanent changes in existing facilities. If Contractor and Owner are unable to agree on entitlement to or on the amount or extent, if any, of any adjustment in the Contract Price or Contract Times, or both, as a result of any delay in Owner's furnishing the Site or a part thereof, Contractor may make a Claim therefor as provided in Paragraph 10.05.

B. Upon reasonable written request, Owner shall furnish Contractor with a current statement of record legal title and legal description of the lands upon which the Work is to be performed and Owner's interest therein as necessary for giving notice of or filing a mechanic's or construction lien against such lands in accordance with applicable Laws and Regulations.

C. Contractor shall provide for all additional lands and access thereto that may be required for temporary construction facilities or storage of materials and equipment.

4.02 *Subsurface and Physical Conditions*

A. *Reports and Drawings*: The Supplementary Conditions identify:

1. those reports of explorations and tests of subsurface conditions at or contiguous to the Site that Engineer has used in preparing the Contract Documents; and

2. those drawings of physical conditions in or relating to existing surface or subsurface structures at or contiguous to the Site (except Underground Facilities) that Engineer has used in preparing the Contract Documents.

B. *Limited Reliance by Contractor on Technical Data Authorized*: Contractor may rely upon the general accuracy of the "technical data" contained in such reports and drawings, but such reports and drawings are not Contract Documents. Such "technical data" is identified in the Supplementary Conditions. Except for such reliance on such "technical data," Contractor may not rely upon or make any claim against Owner or Engineer, or any of their Related Entities with respect to:

1. the completeness of such reports and drawings for Contractor's purposes, including, but not limited to, any aspects of the means, methods, techniques, sequences, and procedures of construction to be employed by Contractor, and safety precautions and programs incident thereto; or

2. other data, interpretations, opinions, and information contained in such reports or shown or indicated in such drawings; or

3. any Contractor interpretation of or conclusion drawn from any "technical data" or any such other data, interpretations, opinions, or information.

4.03 *Differing Subsurface or Physical Conditions*

A. *Notice*: If Contractor believes that any subsurface or physical condition at or contiguous to the Site that is uncovered or revealed either:

1. is of such a nature as to establish that any "technical data" on which Contractor is entitled to rely as provided in Paragraph 4.02 is materially inaccurate; or

2. is of such a nature as to require a change in the Contract Documents; or

3. differs materially from that shown or indicated in the Contract Documents; or

4. is of an unusual nature, and differs materially from conditions ordinarily encountered and generally recognized as inherent in work of the character provided for in the Contract Documents;

then Contractor shall, promptly after becoming aware thereof and before further disturbing the subsurface or physical conditions or performing any Work in connection therewith (except in an emergency as required by Paragraph 6.16.A), notify Owner and Engineer in writing about such condition. Contractor shall not further disturb such condition or perform any Work in connection therewith (except as aforesaid) until receipt of written order to do so.

B. *Engineer's Review*: After receipt of written notice as required by Paragraph 4.03.A, Engineer will promptly review the pertinent condition, determine the necessity of Owner's obtaining additional exploration or tests with respect thereto, and advise Owner in writing (with a copy to Contractor) of Engineer's findings and conclusions.

C. Possible Price and Times Adjustments

1. The Contract Price or the Contract Times, or both, will be equitably adjusted to the extent that the existence of such differing subsurface or physical condition causes an increase or decrease in Contractor's cost of, or time required for, performance of the Work; subject, however, to the following:

a. such condition must meet any one or more of the categories described in Paragraph 4.03.A; and

b. with respect to Work that is paid for on a Unit Price Basis, any adjustment in Contract Price will be subject to the provisions of Paragraphs 9.07 and 11.03.

2. Contractor shall not be entitled to any adjustment in the Contract Price or Contract Times if:

a. Contractor knew of the existence of such conditions at the time Contractor made a final commitment to Owner with respect to Contract Price and Contract Times by the submission of a Bid or becoming bound under a negotiated contract; or

b. the existence of such condition could reasonably have been discovered or revealed as a result of any examination, investigation, exploration, test, or study of the Site and contiguous areas required by the Bidding Requirements or Contract Documents to be conducted by or for Contractor prior to Contractor's making such final commitment; or

c. Contractor failed to give the written notice as required by Paragraph 4.03.A.

3. If Owner and Contractor are unable to agree on entitlement to or on the amount or extent, if any, of any adjustment in the Contract Price or Contract Times, or both, a Claim may be made therefor as provided in Paragraph 10.05. However, Owner and Engineer, and any of their Related Entities shall not be liable to Contractor for any claims, costs, losses, or damages (including but not limited to all fees and charges of engineers, architects, attorneys, and other professionals and all court or arbitration or other dispute resolution costs) sustained by Contractor on or in connection with any other project or anticipated project.

4.04 *Underground Facilities*

A. *Shown or Indicated:* The information and data shown or indicated in the Contract Documents with respect to existing Underground Facilities at or contiguous to the Site is based on information and data furnished to Owner or Engineer by the owners of such Underground Facilities, including Owner, or by others. Unless it is otherwise expressly provided in the Supplementary Conditions:

1. Owner and Engineer shall not be responsible for the accuracy or completeness of any such information or data; and

2. the cost of all of the following will be included in the Contract Price, and Contractor shall have full responsibility for:

- a. reviewing and checking all such information and data,
- b. locating all Underground Facilities shown or indicated in the Contract Documents,
- c. coordination of the Work with the owners of such Underground Facilities, including Owner, during construction, and
- d. the safety and protection of all such Underground Facilities and repairing any damage thereto resulting from the Work.

B. *Not Shown or Indicated*

1. If an Underground Facility is uncovered or revealed at or contiguous to the Site which was not shown or indicated, or not shown or indicated with reasonable accuracy in the Contract Documents, Contractor shall, promptly after becoming aware thereof and before further disturbing conditions affected thereby or performing any Work in connection therewith (except in an emergency as required by Paragraph 6.16.A), identify the owner of such Underground Facility and give written notice to that owner and to Owner and Engineer. Engineer will

promptly review the Underground Facility and determine the extent, if any, to which a change is required in the Contract Documents to reflect and document the consequences of the existence or location of the Underground Facility. During such time, Contractor shall be responsible for the safety and protection of such Underground Facility.

2. If Engineer concludes that a change in the Contract Documents is required, a Work Change Directive or a Change Order will be issued to reflect and document such consequences. An equitable adjustment shall be made in the Contract Price or Contract Times, or both, to the extent that they are attributable to the existence or location of any Underground Facility that was not shown or indicated or not shown or indicated with reasonable accuracy in the Contract Documents and that Contractor did not know of and could not reasonably have been expected to be aware of or to have anticipated. If Owner and Contractor are unable to agree on entitlement to or on the amount or extent, if any, of any such adjustment in Contract Price or Contract Times, Owner or Contractor may make a Claim therefor as provided in Paragraph 10.05.

4.05 *Reference Points*

A. Owner shall provide engineering surveys to establish reference points for construction which in Engineer's judgment are necessary to enable Contractor to proceed with the Work. Contractor shall be responsible for laying out the Work, shall protect and preserve the established reference points and property monuments, and shall make no changes or relocations without the prior written approval of Owner. Contractor shall report to Engineer whenever any reference point or property monument is lost or destroyed or requires relocation because of necessary changes in grades or locations, and shall be responsible for the accurate replacement or relocation of such reference points or property monuments by professionally qualified personnel.

4.06 *Hazardous Environmental Condition at Site*

A. *Reports and Drawings:* Reference is made to the Supplementary Conditions for the identification of those reports and drawings relating to a Hazardous Environmental Condition identified at the Site, if any, that have been utilized by the Engineer in the preparation of the Contract Documents.

B. *Limited Reliance by Contractor on Technical Data Authorized:* Contractor may rely upon the general accuracy of the "technical data" contained in such reports and drawings, but such reports and drawings are not Contract Documents. Such "technical data" is identified in the Supplementary Conditions. Except for such reliance on such "technical data," Contractor may not rely upon or make any claim against Owner or Engineer, or any of their Related Entities with respect to:

1. the completeness of such reports and drawings for Contractor's purposes, including, but not limited to, any aspects of the means, methods, techniques, sequences and procedures of construction to be employed by Contractor and safety precautions and programs incident thereto; or

2. other data, interpretations, opinions and information contained in such reports or shown or indicated in such drawings; or

3. any Contractor interpretation of or conclusion drawn from any "technical data" or any such other data, interpretations, opinions or information.

C. Contractor shall not be responsible for any Hazardous Environmental Condition uncovered or revealed at the Site which was not shown or indicated in Drawings or Specifications or identified in the Contract Documents to be within the scope of the Work. Contractor shall be responsible for a Hazardous Environmental Condition created with any materials brought to the Site by Contractor, Subcontractors, Suppliers, or anyone else for whom Contractor is responsible.

D. If Contractor encounters a Hazardous Environmental Condition or if Contractor or anyone for whom Contractor is responsible creates a Hazardous Environmental Condition, Contractor shall immediately: (i) secure or otherwise isolate such condition; (ii) stop all Work in connection with such condition and in any area affected thereby (except in an emergency as required by Paragraph 6.16.A); and (iii) notify Owner and Engineer (and promptly thereafter confirm such notice in writing). Owner shall promptly consult with Engineer concerning the necessity for Owner to retain a qualified expert to evaluate such condition or take corrective action, if any.

E. Contractor shall not be required to resume Work in connection with such condition or in any affected area until after Owner has obtained any required permits related thereto and delivered to Contractor written notice: (i) specifying that such condition and any affected area is or has been rendered safe for the resumption of Work; or (ii) specifying any special conditions under which such Work may be resumed safely. If Owner and Contractor cannot agree as to entitlement to or on the amount or extent, if any, of any adjustment in Contract Price or Contract Times, or both, as a result of such Work stoppage or such special conditions under which Work is agreed to be resumed by Contractor, either party may make a Claim therefor as provided in Paragraph 10.05.

F. If after receipt of such written notice Contractor does not agree to resume such Work based on a reasonable belief it is unsafe, or does not agree to resume such Work under such special conditions, then Owner may order the portion of the Work that is in the area affected by such condition to be deleted from the Work. If Owner and Contractor cannot agree as to

entitlement to or on the amount or extent, if any, of an adjustment in Contract Price or Contract Times as a result of deleting such portion of the Work, then either party may make a Claim therefor as provided in Paragraph 10.05. Owner may have such deleted portion of the Work performed by Owner's own forces or others in accordance with Article 7.

G. To the fullest extent permitted by Laws and Regulations, Owner shall indemnify and hold harmless Contractor, Subcontractors, and Engineer, and the officers, directors, partners, employees, agents, consultants, and subcontractors of each and any of them from and against all claims, costs, losses, and damages (including but not limited to all fees and charges of engineers, architects, attorneys, and other professionals and all court or arbitration or other dispute resolution costs) arising out of or relating to a Hazardous Environmental Condition, provided that such Hazardous Environmental Condition: (i) was not shown or indicated in the Drawings or Specifications or identified in the Contract Documents to be included within the scope of the Work, and (ii) was not created by Contractor or by anyone for whom Contractor is responsible. Nothing in this Paragraph 4.06. G shall obligate Owner to indemnify any individual or entity from and against the consequences of that individual's or entity's own negligence.

H. To the fullest extent permitted by Laws and Regulations, Contractor shall indemnify and hold harmless Owner and Engineer, and the officers, directors, partners, employees, agents, consultants, and subcontractors of each and any of them from and against all claims, costs, losses, and damages (including but not limited to all fees and charges of engineers, architects, attorneys, and other professionals and all court or arbitration or other dispute resolution costs) arising out of or relating to a Hazardous Environmental Condition created by Contractor or by anyone for whom Contractor is responsible. Nothing in this Paragraph 4.06.H shall obligate Contractor to indemnify any individual or entity from and against the consequences of that individual's or entity's own negligence.

I. The provisions of Paragraphs 4.02, 4.03, and 4.04 do not apply to a Hazardous Environmental Condition uncovered or revealed at the Site.

ARTICLE 5 - BONDS AND INSURANCE

5.01 *Performance, Payment, and Other Bonds*

A. Contractor shall furnish performance and payment bonds, each in an amount at least equal to the Contract Price as security for the faithful performance and payment of all of Contractor's obligations under the Contract Documents. These bonds shall remain in effect until one year after the date when final payment becomes due or until completion of the correction period specified

in Paragraph 13.07, whichever is later, except as provided otherwise by Laws or Regulations or by the Contract Documents. Contractor shall also furnish such other bonds as are required by the Contract Documents.

B. All bonds shall be in the form prescribed by the Contract Documents except as provided otherwise by Laws or Regulations, and shall be executed by such sureties as are named in the current list of "Companies Holding Certificates of Authority as Acceptable Sureties on Federal Bonds and as Acceptable Reinsuring Companies" as published in Circular 570 (amended) by the Financial Management Service, Surety Bond Branch, U.S. Department of the Treasury. All bonds signed by an agent must be accompanied by a certified copy of the agent's authority to act.

C. If the surety on any bond furnished by Contractor is declared bankrupt or becomes insolvent or its right to do business is terminated in any state where any part of the Project is located or it ceases to meet the requirements of Paragraph 5.01.B, Contractor shall promptly notify Owner and Engineer and shall, within 20 days after the event giving rise to such notification, provide another bond and surety, both of which shall comply with the requirements of Paragraphs 5.01.B and 5.02.

5.02 *Licensed Sureties and Insurers*

A. All bonds and insurance required by the Contract Documents to be purchased and maintained by Owner or Contractor shall be obtained from surety or insurance companies that are duly licensed or authorized in the jurisdiction in which the Project is located to issue bonds or insurance policies for the limits and coverages so required. Such surety and insurance companies shall also meet such additional requirements and qualifications as may be provided in the Supplementary Conditions.

5.03 *Certificates of Insurance*

A. Contractor shall deliver to Owner, with copies to each additional insured identified in the Supplementary Conditions, certificates of insurance (and other evidence of insurance requested by Owner or any other additional insured) which Contractor is required to purchase and maintain.

B. Owner shall deliver to Contractor, with copies to each additional insured identified in the Supplementary Conditions, certificates of insurance (and other evidence of insurance requested by Contractor or any other additional insured) which Owner is required to purchase and maintain.

5.04 *Contractor's Liability Insurance*

A. Contractor shall purchase and maintain such liability and other insurance as is appropriate for the Work being performed and as will provide protection

from claims set forth below which may arise out of or result from Contractor's performance of the Work and Contractor's other obligations under the Contract Documents, whether it is to be performed by Contractor, any Subcontractor or Supplier, or by anyone directly or indirectly employed by any of them to perform any of the Work, or by anyone for whose acts any of them may be liable:

1. claims under workers' compensation, disability benefits, and other similar employee benefit acts;

2. claims for damages because of bodily injury, occupational sickness or disease, or death of Contractor's employees;

3. claims for damages because of bodily injury, sickness or disease, or death of any person other than Contractor's employees;

4. claims for damages insured by reasonably available personal injury liability coverage which are sustained:

a. by any person as a result of an offense directly or indirectly related to the employment of such person by Contractor, or

b. by any other person for any other reason;

5. claims for damages, other than to the Work itself, because of injury to or destruction of tangible property wherever located, including loss of use resulting therefrom; and

6. claims for damages because of bodily injury or death of any person or property damage arising out of the ownership, maintenance or use of any motor vehicle.

B. The policies of insurance required by this Paragraph 5.04 shall:

1. with respect to insurance required by Paragraphs 5.04.A.3 through 5.04.A.6 inclusive, include as additional insured (subject to any customary exclusion regarding professional liability) Owner and Engineer, and any other individuals or entities identified in the Supplementary Conditions, all of whom shall be listed as additional insureds, and include coverage for the respective officers, directors, partners, employees, agents, consultants and subcontractors of each and any of all such additional insureds, and the insurance afforded to these additional insureds shall provide primary coverage for all claims covered thereby;

2. include at least the specific coverages and be written for not less than the limits of liability provided in the Supplementary Conditions or required by Laws or Regulations, whichever is greater;

3. include completed operations insurance;

4. include contractual liability insurance covering Contractor's indemnity obligations under Paragraphs 6.11 and 6.20;

5. contain a provision or endorsement that the coverage afforded will not be canceled, materially changed or renewal refused until at least 30 days prior written notice has been given to Owner and Contractor and to each other additional insured identified in the Supplementary Conditions to whom a certificate of insurance has been issued (and the certificates of insurance furnished by the Contractor pursuant to Paragraph 5.03 will so provide);

6. remain in effect at least until final payment and at all times thereafter when Contractor may be correcting, removing, or replacing defective Work in accordance with Paragraph 13.07; and

7. with respect to completed operations insurance, and any insurance coverage written on a claims-made basis, remain in effect for at least two years after final payment.

a. Contractor shall furnish Owner and each other additional insured identified in the Supplementary Conditions, to whom a certificate of insurance has been issued, evidence satisfactory to Owner and any such additional insured of continuation of such insurance at final payment and one year thereafter.

5.05 *Owner's Liability Insurance*

A. In addition to the insurance required to be provided by Contractor under Paragraph 5.04, Owner, at Owner's option, may purchase and maintain at Owner's expense Owner's own liability insurance as will protect Owner against claims which may arise from operations under the Contract Documents.

5.06 *Property Insurance*

A. Unless otherwise provided in the Supplementary Conditions, Owner shall purchase and maintain property insurance upon the Work at the Site in the amount of the full replacement cost thereof (subject to such deductible amounts as may be provided in the Supplementary Conditions or required by Laws and Regulations). This insurance shall:

1. include the interests of Owner, Contractor, Subcontractors, and Engineer, and any other individuals or entities identified in the Supplementary Conditions, and the officers, directors, partners, employees, agents, consultants and subcontractors of each and any of them, each of whom is deemed to have an insurable interest and shall be listed as an insured or additional insured;

2. be written on a Builder's Risk "all-risk" or open peril or special causes of loss policy form that shall at least include insurance for physical loss or damage to the Work, temporary buildings, false work, and materials and equipment in transit, and shall insure against at least the following perils or causes of loss: fire, lightning, extended coverage, theft, vandalism and malicious mischief, earthquake, collapse, debris removal, demolition occasioned by enforcement of Laws and Regulations, water damage, (other than caused by flood) and such other perils or causes of loss as may be specifically required by the Supplementary Conditions;

3. include expenses incurred in the repair or replacement of any insured property (including but not limited to fees and charges of engineers and architects);

4. cover materials and equipment stored at the Site or at another location that was agreed to in writing by Owner prior to being incorporated in the Work, provided that such materials and equipment have been included in an Application for Payment recommended by Engineer;

5. allow for partial utilization of the Work by Owner;

6. include testing and startup; and

7. be maintained in effect until final payment is made unless otherwise agreed to in writing by Owner, Contractor, and Engineer with 30 days written notice to each other additional insured to whom a certificate of insurance has been issued.

B. Owner shall purchase and maintain such boiler and machinery insurance or additional property insurance as may be required by the Supplementary Conditions or Laws and Regulations which will include the interests of Owner, Contractor, Subcontractors, and Engineer, and any other individuals or entities identified in the Supplementary Conditions, and the officers, directors, partners, employees, agents, consultants and subcontractors of each and any of them, each of whom is deemed to have an insurable interest and shall be listed as an insured or additional insured.

C. All the policies of insurance (and the certificates or other evidence thereof) required to be purchased and maintained in accordance with Paragraph 5.06 will contain a provision or endorsement that the coverage afforded will not be canceled or materially changed or renewal refused until at least 30 days prior written notice has been given to Owner and Contractor and to each other additional insured to whom a certificate of insurance has been issued and will contain waiver provisions in accordance with Paragraph 5.07.

D. Owner shall not be responsible for purchasing and maintaining any property insurance specified in this Paragraph 5.06 to protect the interests of Contractor, Subcontractors, or others in the Work to the extent of any

deductible amounts that are identified in the Supplementary Conditions. The risk of loss within such identified deductible amount will be borne by Contractor, Subcontractors, or others suffering any such loss, and if any of them wishes property insurance coverage within the limits of such amounts, each may purchase and maintain it at the purchaser's own expense.

E. If Contractor requests in writing that other special insurance be included in the property insurance policies provided under Paragraph 5.06, Owner shall, if possible, include such insurance, and the cost thereof will be charged to Contractor by appropriate Change Order. Prior to commencement of the Work at the Site, Owner shall in writing advise Contractor whether or not such other insurance has been procured by Owner.

5.07 *Waiver of Rights*

A. Owner and Contractor intend that all policies purchased in accordance with Paragraph 5.06 will protect Owner, Contractor, Subcontractors, and Engineer, and all other individuals or entities identified in the Supplementary Conditions to be listed as insureds or additional insureds (and the officers, directors, partners, employees, agents, consultants and subcontractors of each and any of them) in such policies and will provide primary coverage for all losses and damages caused by the perils or causes of loss covered thereby. All such policies shall contain provisions to the effect that in the event of payment of any loss or damage the insurers will have no rights of recovery against any of the insureds or additional insureds thereunder. Owner and Contractor waive all rights against each other and their respective officers, directors, partners, employees, agents, consultants and subcontractors of each and any of them for all losses and damages caused by, arising out of or resulting from any of the perils or causes of loss covered by such policies and any other property insurance applicable to the Work; and, in addition, waive all such rights against Subcontractors, and Engineer, and all other individuals or entities identified in the Supplementary Conditions to be listed as insured or additional insured (and the officers, directors, partners, employees, agents, consultants and subcontractors of each and any of them) under such policies for losses and damages so caused. None of the above waivers shall extend to the rights that any party making such waiver may have to the proceeds of insurance held by Owner as trustee or otherwise payable under any policy so issued.

B. Owner waives all rights against Contractor, Subcontractors, and Engineer, and the officers, directors, partners, employees, agents, consultants and subcontractors of each and any of them for:

1. loss due to business interruption, loss of use, or other consequential loss extending beyond direct physical loss or damage to Owner's property or the Work caused by, arising out of, or resulting from fire or other perils whether or not insured by Owner; and

2. loss or damage to the completed Project or part thereof caused by, arising out of, or resulting from fire or other insured peril or cause of loss covered by any property insurance maintained on the completed Project or part thereof by Owner during partial utilization pursuant to Paragraph 14.05, after Substantial Completion pursuant to Paragraph 14.04, or after final payment pursuant to Paragraph 14.07.

C. Any insurance policy maintained by Owner covering any loss, damage or consequential loss referred to in Paragraph 5.07.B shall contain provisions to the effect that in the event of payment of any such loss, damage, or consequential loss, the insurers will have no rights of recovery against Contractor, Subcontractors, or Engineer, and the officers, directors, partners, employees, agents, consultants and subcontractors of each and any of them.

5.08 *Receipt and Application of Insurance Proceeds*

A. Any insured loss under the policies of insurance required by Paragraph 5.06 will be adjusted with Owner and made payable to Owner as fiduciary for the insureds, as their interests may appear, subject to the requirements of any applicable mortgage clause and of Paragraph 5.08.B. Owner shall deposit in a separate account any money so received and shall distribute it in accordance with such agreement as the parties in interest may reach. If no other special agreement is reached, the damaged Work shall be repaired or replaced, the moneys so received applied on account thereof, and the Work and the cost thereof covered by an appropriate Change Order .

B. Owner as fiduciary shall have power to adjust and settle any loss with the insurers unless one of the parties in interest shall object in writing within 15 days after the occurrence of loss to Owner's exercise of this power. If such objection be made, Owner as fiduciary shall make settlement with the insurers in accordance with such agreement as the parties in interest may reach. If no such agreement among the parties in interest is reached, Owner as fiduciary shall adjust and settle the loss with the insurers and, if required in writing by any party in interest, Owner as fiduciary shall give bond for the proper performance of such duties.

5.09 *Acceptance of Bonds and Insurance; Option to Replace*

A. If either Owner or Contractor has any objection to the coverage afforded by or other provisions of the bonds or insurance required to be purchased and maintained by the other party in accordance with Article 5 on the basis of non-conformance with the Contract

Documents, the objecting party shall so notify the other party in writing within 10 days after receipt of the certificates (or other evidence requested) required by Paragraph 2.01.B. Owner and Contractor shall each provide to the other such additional information in respect of insurance provided as the other may reasonably request. If either party does not purchase or maintain all of the bonds and insurance required of such party by the Contract Documents, such party shall notify the other party in writing of such failure to purchase prior to the start of the Work, or of such failure to maintain prior to any change in the required coverage. Without prejudice to any other right or remedy, the other party may elect to obtain equivalent bonds or insurance to protect such other party's interests at the expense of the party who was required to provide such coverage, and a Change Order shall be issued to adjust the Contract Price accordingly.

5.10 *Partial Utilization, Acknowledgment of Property Insurer*

A. If Owner finds it necessary to occupy or use a portion or portions of the Work prior to Substantial Completion of all the Work as provided in Paragraph 14.05, no such use or occupancy shall commence before the insurers providing the property insurance pursuant to Paragraph 5.06 have acknowledged notice thereof and in writing effected any changes in coverage necessitated thereby. The insurers providing the property insurance shall consent by endorsement on the policy or policies, but the property insurance shall not be canceled or permitted to lapse on account of any such partial use or occupancy.

ARTICLE 6 - CONTRACTOR'S RESPONSIBILITIES

6.01 *Supervision and Superintendence*

A. Contractor shall supervise, inspect, and direct the Work competently and efficiently, devoting such attention thereto and applying such skills and expertise as may be necessary to perform the Work in accordance with the Contract Documents. Contractor shall be solely responsible for the means, methods, techniques, sequences, and procedures of construction. Contractor shall not be responsible for the negligence of Owner or Engineer in the design or specification of a specific means, method, technique, sequence, or procedure of construction which is shown or indicated in and expressly required by the Contract Documents.

B. At all times during the progress of the Work, Contractor shall assign a competent resident superintendent who shall not be replaced without written notice to Owner and Engineer except under extraordinary circumstances. The superintendent will be Contractor's representative at the Site and shall have authority to act on behalf of Contractor. All communications given to or

received from the superintendent shall be binding on Contractor.

6.02 *Labor; Working Hours*

A. Contractor shall provide competent, suitably qualified personnel to survey and lay out the Work and perform construction as required by the Contract Documents. Contractor shall at all times maintain good discipline and order at the Site.

B. Except as otherwise required for the safety or protection of persons or the Work or property at the Site or adjacent thereto, and except as otherwise stated in the Contract Documents, all Work at the Site shall be performed during regular working hours. Contractor will not permit the performance of Work on a Saturday, Sunday, or any legal holiday without Owner's written consent (which will not be unreasonably withheld) given after prior written notice to Engineer.

6.03 *Services, Materials, and Equipment*

A. Unless otherwise specified in the Contract Documents, Contractor shall provide and assume full responsibility for all services, materials, equipment, labor, transportation, construction equipment and machinery, tools, appliances, fuel, power, light, heat, telephone, water, sanitary facilities, temporary facilities, and all other facilities and incidentals necessary for the performance, testing, start-up, and completion of the Work.

B. All materials and equipment incorporated into the Work shall be as specified or, if not specified, shall be of good quality and new, except as otherwise provided in the Contract Documents. All special warranties and guarantees required by the Specifications shall expressly run to the benefit of Owner. If required by Engineer, Contractor shall furnish satisfactory evidence (including reports of required tests) as to the source, kind, and quality of materials and equipment.

C. All materials and equipment shall be stored, applied, installed, connected, erected, protected, used, cleaned, and conditioned in accordance with instructions of the applicable Supplier, except as otherwise may be provided in the Contract Documents.

6.04 *Progress Schedule*

A. Contractor shall adhere to the Progress Schedule established in accordance with Paragraph 2.07 as it may be adjusted from time to time as provided below.

1. Contractor shall submit to Engineer for acceptance (to the extent indicated in Paragraph 2.07) proposed adjustments in the Progress Schedule that will not result in changing the Contract Times. Such adjustments will comply with any provisions of the General Requirements applicable thereto.

2. Proposed adjustments in the Progress Schedule that will change the Contract Times shall be submitted in accordance with the requirements of Article 12. Adjustments in Contract Times may only be made by a Change Order.

6.05 *Substitutes and "Or-Equals"*

A. Whenever an item of material or equipment is specified or described in the Contract Documents by using the name of a proprietary item or the name of a particular Supplier, the specification or description is intended to establish the type, function, appearance, and quality required. Unless the specification or description contains or is followed by words reading that no like, equivalent, or "or-equal" item or no substitution is permitted, other items of material or equipment or material or equipment of other Suppliers may be submitted to Engineer for review under the circumstances described below.

1. *"Or-Equal" Items:* If in Engineer's sole discretion an item of material or equipment proposed by Contractor is functionally equal to that named and sufficiently similar so that no change in related Work will be required, it may be considered by Engineer as an "or-equal" item, in which case review and approval of the proposed item may, in Engineer's sole discretion, be accomplished without compliance with some or all of the requirements for approval of proposed substitute items. For the purposes of this Paragraph 6.05.A.1, a proposed item of material or equipment will be considered functionally equal to an item so named if:

a. in the exercise of reasonable judgment Engineer determines that:

1) it is at least equal in materials of construction, quality, durability, appearance, strength, and design characteristics;

2) it will reliably perform at least equally well the function and achieve the results imposed by the design concept of the completed Project as a functioning whole,

3) it has a proven record of performance and availability of responsive service; and

b. Contractor certifies that, if approved and incorporated into the Work:

1) there will be no increase in cost to the Owner or increase in Contract Times, and

2) it will conform substantially to the detailed requirements of the item named in the Contract Documents.

2. Substitute Items

a. If in Engineer's sole discretion an item of material or equipment proposed by Contractor does not qualify as an "or-equal" item under Paragraph 6.05.A.1, it will be considered a proposed substitute item.

b. Contractor shall submit sufficient information as provided below to allow Engineer to determine that the item of material or equipment proposed is essentially equivalent to that named and an acceptable substitute therefor. Requests for review of proposed substitute items of material or equipment will not be accepted by Engineer from anyone other than Contractor.

c. The requirements for review by Engineer will be as set forth in Paragraph 6.05.A.2.d, as supplemented in the General Requirements and as Engineer may decide is appropriate under the circumstances.

d. Contractor shall make written application to Engineer for review of a proposed substitute item of material or equipment that Contractor seeks to furnish or use. The application:

1) shall certify that the proposed substitute item will:

a) perform adequately the functions and achieve the results called for by the general design,

b) be similar in substance to that specified, and

c) be suited to the same use as that specified;

2) will state:

a) the extent, if any, to which the use of the proposed substitute item will prejudice Contractor's achievement of Substantial Completion on time;

b) whether or not use of the proposed substitute item in the Work will require a change in any of the Contract Documents (or in the provisions of any other direct contract with Owner for other work on the Project) to adapt the design to the proposed substitute item; and

c) whether or not incorporation or use of the proposed substitute item in connection with the Work is subject to payment of any license fee or royalty;

3) will identify:

a) all variations of the proposed substitute item from that specified, and

b) available engineering, sales, maintenance, repair, and replacement services;

4) and shall contain an itemized estimate of all costs or credits that will result directly or indirectly from use of such substitute item, including costs of redesign and claims of other contractors affected by any resulting change,

B. Substitute Construction Methods or Procedures: If a specific means, method, technique, sequence, or procedure of construction is expressly required by the Contract Documents, Contractor may furnish or utilize a substitute means, method, technique, sequence, or procedure of construction approved by Engineer. Contractor shall submit sufficient information to allow Engineer, in Engineer's sole discretion, to determine that the substitute proposed is equivalent to that expressly called for by the Contract Documents. The requirements for review by Engineer will be similar to those provided in Paragraph 6.05.A.2.

C. Engineer's Evaluation: Engineer will be allowed a reasonable time within which to evaluate each proposal or submittal made pursuant to Paragraphs 6.05.A and 6.05.B. Engineer may require Contractor to furnish additional data about the proposed substitute item. Engineer will be the sole judge of acceptability. No "or equal" or substitute will be ordered, installed or utilized until Engineer's review is complete, which will be evidenced by either a Change Order for a substitute or an approved Shop Drawing for an "or equal." Engineer will advise Contractor in writing of any negative determination.

D. Special Guarantee: Owner may require Contractor to furnish at Contractor's expense a special performance guarantee or other surety with respect to any substitute.

E. Engineer's Cost Reimbursement: Engineer will record Engineer's costs in evaluating a substitute proposed or submitted by Contractor pursuant to Paragraphs 6.05.A.2 and 6.05.B. Whether or not Engineer approves a substitute item so proposed or submitted by Contractor, Contractor shall reimburse Owner for the charges of Engineer for evaluating each such proposed substitute. Contractor shall also reimburse Owner for the charges of Engineer for making changes in the Contract

Documents (or in the provisions of any other direct contract with Owner) resulting from the acceptance of each proposed substitute.

F. Contractor's Expense: Contractor shall provide all data in support of any proposed substitute or "or-equal" at Contractor's expense.

6.06 Concerning Subcontractors, Suppliers, and Others

A. Contractor shall not employ any Subcontractor, Supplier, or other individual or entity (including those acceptable to Owner as indicated in Paragraph 6.06.B), whether initially or as a replacement, against whom Owner may have reasonable objection. Contractor shall not be required to employ any Subcontractor, Supplier, or other individual or entity to furnish or perform any of the Work against whom Contractor has reasonable objection.

B. If the Supplementary Conditions require the identity of certain Subcontractors, Suppliers, or other individuals or entities to be submitted to Owner in advance for acceptance by Owner by a specified date prior to the Effective Date of the Agreement, and if Contractor has submitted a list thereof in accordance with the Supplementary Conditions, Owner's acceptance (either in writing or by failing to make written objection thereto by the date indicated for acceptance or objection in the Bidding Documents or the Contract Documents) of any such Subcontractor, Supplier, or other individual or entity so identified may be revoked on the basis of reasonable objection after due investigation. Contractor shall submit an acceptable replacement for the rejected Subcontractor, Supplier, or other individual or entity, and the Contract Price will be adjusted by the difference in the cost occasioned by such replacement, and an appropriate Change Order will be issued. No acceptance by Owner of any such Subcontractor, Supplier, or other individual or entity, whether initially or as a replacement, shall constitute a waiver of any right of Owner or Engineer to reject defective Work.

C. Contractor shall be fully responsible to Owner and Engineer for all acts and omissions of the Subcontractors, Suppliers, and other individuals or entities performing or furnishing any of the Work just as Contractor is responsible for Contractor's own acts and omissions. Nothing in the Contract Documents:

1. shall create for the benefit of any such Subcontractor, Supplier, or other individual or entity any contractual relationship between Owner or Engineer and any such Subcontractor, Supplier or other individual or entity, nor

2. shall anything in the Contract Documents create any obligation on the part of Owner or Engineer to pay or to see to the payment of any moneys due any such Subcontractor, Supplier, or other individual

or entity except as may otherwise be required by Laws and Regulations.

D. Contractor shall be solely responsible for scheduling and coordinating the Work of Subcontractors, Suppliers, and other individuals or entities performing or furnishing any of the Work under a direct or indirect contract with Contractor.

E. Contractor shall require all Subcontractors, Suppliers, and such other individuals or entities performing or furnishing any of the Work to communicate with Engineer through Contractor.

F. The divisions and sections of the Specifications and the identifications of any Drawings shall not control Contractor in dividing the Work among Subcontractors or Suppliers or delineating the Work to be performed by any specific trade.

G. All Work performed for Contractor by a Subcontractor or Supplier will be pursuant to an appropriate agreement between Contractor and the Subcontractor or Supplier which specifically binds the Subcontractor or Supplier to the applicable terms and conditions of the Contract Documents for the benefit of Owner and Engineer. Whenever any such agreement is with a Subcontractor or Supplier who is listed as an additional insured on the property insurance provided in Paragraph 5.06, the agreement between the Contractor and the Subcontractor or Supplier will contain provisions whereby the Subcontractor or Supplier waives all rights against Owner, Contractor, and Engineer, and all other individuals or entities identified in the Supplementary Conditions to be listed as insureds or additional insureds (and the officers, directors, partners, employees, agents, consultants and subcontractors of each and any of them) for all losses and damages caused by, arising out of, relating to, or resulting from any of the perils or causes of loss covered by such policies and any other property insurance applicable to the Work. If the insurers on any such policies require separate waiver forms to be signed by any Subcontractor or Supplier, Contractor will obtain the same.

6.07 *Patent Fees and Royalties*

A. Contractor shall pay all license fees and royalties and assume all costs incident to the use in the performance of the Work or the incorporation in the Work of any invention, design, process, product, or device which is the subject of patent rights or copyrights held by others. If a particular invention, design, process, product, or device is specified in the Contract Documents for use in the performance of the Work and if to the actual knowledge of Owner or Engineer its use is subject to patent rights or copyrights calling for the payment of any license fee or royalty to others, the existence of such rights shall be disclosed by Owner in the Contract Documents.

B. To the fullest extent permitted by Laws and Regulations, Contractor shall indemnify and hold harmless Owner and Engineer, and the officers, directors, partners, employees, agents, consultants and subcontractors of each and any of them from and against all claims, costs, losses, and damages (including but not limited to all fees and charges of engineers, architects, attorneys, and other professionals and all court or arbitration or other dispute resolution costs) arising out of or relating to any infringement of patent rights or copyrights incident to the use in the performance of the Work or resulting from the incorporation in the Work of any invention, design, process, product, or device not specified in the Contract Documents.

6.08 *Permits*

A. Unless otherwise provided in the Supplementary Conditions, Contractor shall obtain and pay for all construction permits and licenses. Owner shall assist Contractor, when necessary, in obtaining such permits and licenses. Contractor shall pay all governmental charges and inspection fees necessary for the prosecution of the Work which are applicable at the time of opening of Bids, or, if there are no Bids, on the Effective Date of the Agreement. Owner shall pay all charges of utility owners for connections for providing permanent service to the Work.

6.09 *Laws and Regulations*

A. Contractor shall give all notices required by and shall comply with all Laws and Regulations applicable to the performance of the Work. Except where otherwise expressly required by applicable Laws and Regulations, neither Owner nor Engineer shall be responsible for monitoring Contractor's compliance with any Laws or Regulations.

B. If Contractor performs any Work knowing or having reason to know that it is contrary to Laws or Regulations, Contractor shall bear all claims, costs, losses, and damages (including but not limited to all fees and charges of engineers, architects, attorneys, and other professionals and all court or arbitration or other dispute resolution costs) arising out of or relating to such Work. However, it shall not be Contractor's primary responsibility to make certain that the Specifications and Drawings are in accordance with Laws and Regulations, but this shall not relieve Contractor of Contractor's obligations under Paragraph 3.03.

C. Changes in Laws or Regulations not known at the time of opening of Bids (or, on the Effective Date of the Agreement if there were no Bids) having an effect on the cost or time of performance of the Work shall be the subject of an adjustment in Contract Price or Contract Times. If Owner and Contractor are unable to agree on entitlement to or on the amount or extent, if any, of any such adjustment, a Claim may be made therefor as provided in Paragraph 10.05.

6.10 *Taxes*

A. Contractor shall pay all sales, consumer, use, and other similar taxes required to be paid by Contractor in accordance with the Laws and Regulations of the place of the Project which are applicable during the performance of the Work.

6.11 *Use of Site and Other Areas*

A. Limitation on Use of Site and Other Areas

1. Contractor shall confine construction equipment, the storage of materials and equipment, and the operations of workers to the Site and other areas permitted by Laws and Regulations, and shall not unreasonably encumber the Site and other areas with construction equipment or other materials or equipment. Contractor shall assume full responsibility for any damage to any such land or area, or to the owner or occupant thereof, or of any adjacent land or areas resulting from the performance of the Work.

2. Should any claim be made by any such owner or occupant because of the performance of the Work, Contractor shall promptly settle with such other party by negotiation or otherwise resolve the claim by arbitration or other dispute resolution proceeding or at law.

3. To the fullest extent permitted by Laws and Regulations, Contractor shall indemnify and hold harmless Owner and Engineer, and the officers, directors, partners, employees, agents, consultants and subcontractors of each and any of them from and against all claims, costs, losses, and damages (including but not limited to all fees and charges of engineers, architects, attorneys, and other professionals and all court or arbitration or other dispute resolution costs) arising out of or relating to any claim or action, legal or equitable, brought by any such owner or occupant against Owner, Engineer, or any other party indemnified hereunder to the extent caused by or based upon Contractor's performance of the Work.

B. *Removal of Debris During Performance of the Work:* During the progress of the Work Contractor shall keep the Site and other areas free from accumulations of waste materials, rubbish, and other debris. Removal and disposal of such waste materials, rubbish, and other debris shall conform to applicable Laws and Regulations.

C. *Cleaning:* Prior to Substantial Completion of the Work Contractor shall clean the Site and the Work and make it ready for utilization by Owner. At the completion of the Work Contractor shall remove from the Site all tools, appliances, construction equipment and machinery, and surplus materials and shall restore to original condition all property not designated for alteration by the Contract Documents.

D. *Loading Structures:* Contractor shall not load nor permit any part of any structure to be loaded in any manner that will endanger the structure, nor shall Contractor subject any part of the Work or adjacent property to stresses or pressures that will endanger it.

6.12 *Record Documents*

A. Contractor shall maintain in a safe place at the Site one record copy of all Drawings, Specifications, Addenda, Change Orders, Work Change Directives, Field Orders, and written interpretations and clarifications in good order and annotated to show changes made during construction. These record documents together with all approved Samples and a counterpart of all approved Shop Drawings will be available to Engineer for reference. Upon completion of the Work, these record documents, Samples, and Shop Drawings will be delivered to Engineer for Owner.

6.13 *Safety and Protection*

A. Contractor shall be solely responsible for initiating, maintaining and supervising all safety precautions and programs in connection with the Work. Contractor shall take all necessary precautions for the safety of, and shall provide the necessary protection to prevent damage, injury or loss to:

1. all persons on the Site or who may be affected by the Work;

2. all the Work and materials and equipment to be incorporated therein, whether in storage on or off the Site; and

3. other property at the Site or adjacent thereto, including trees, shrubs, lawns, walks, pavements, roadways, structures, utilities, and Underground Facilities not designated for removal, relocation, or replacement in the course of construction.

B. Contractor shall comply with all applicable Laws and Regulations relating to the safety of persons or property, or to the protection of persons or property from damage, injury, or loss; and shall erect and maintain all necessary safeguards for such safety and protection. Contractor shall notify owners of adjacent property and of Underground Facilities and other utility owners when prosecution of the Work may affect them, and shall cooperate with them in the protection, removal, relocation, and replacement of their property.

C. All damage, injury, or loss to any property referred to in Paragraph 6.13.A.2 or 6.13.A.3 caused, directly or indirectly, in whole or in part, by Contractor, any Subcontractor, Supplier, or any other individual or entity directly or indirectly employed by any of them to perform any of the Work, or anyone for whose acts any of them may be liable, shall be remedied by Contractor (except damage or loss attributable to the fault of Draw-

ings or Specifications or to the acts or omissions of Owner or Engineer or , or anyone employed by any of them, or anyone for whose acts any of them may be liable, and not attributable, directly or indirectly, in whole or in part, to the fault or negligence of Contractor or any Subcontractor, Supplier, or other individual or entity directly or indirectly employed by any of them).

D. Contractor's duties and responsibilities for safety and for protection of the Work shall continue until such time as all the Work is completed and Engineer has issued a notice to Owner and Contractor in accordance with Paragraph 14.07.B that the Work is acceptable (except as otherwise expressly provided in connection with Substantial Completion).

6.14 *Safety Representative*

A. Contractor shall designate a qualified and experienced safety representative at the Site whose duties and responsibilities shall be the prevention of accidents and the maintaining and supervising of safety precautions and programs.

6.15 *Hazard Communication Programs*

A. Contractor shall be responsible for coordinating any exchange of material safety data sheets or other hazard communication information required to be made available to or exchanged between or among employers at the Site in accordance with Laws or Regulations.

6.16 *Emergencies*

A. In emergencies affecting the safety or protection of persons or the Work or property at the Site or adjacent thereto, Contractor is obligated to act to prevent threatened damage, injury, or loss. Contractor shall give Engineer prompt written notice if Contractor believes that any significant changes in the Work or variations from the Contract Documents have been caused thereby or are required as a result thereof. If Engineer determines that a change in the Contract Documents is required because of the action taken by Contractor in response to such an emergency, a Work Change Directive or Change Order will be issued.

6.17 *Shop Drawings and Samples*

A. Contractor shall submit Shop Drawings and Samples to Engineer for review and approval in accordance with the acceptable Schedule of Submittals (as required by Paragraph 2.07). Each submittal will be identified as Engineer may require.

1. Shop Drawings

a. Submit number of copies specified in the General Requirements.

b. Data shown on the Shop Drawings will be complete with respect to quantities, dimensions, specified performance and design criteria, materials, and similar data to show Engineer the services, materials, and equipment Contractor proposes to provide and to enable Engineer to review the information for the limited purposes required by Paragraph 6.17.D.

2. *Samples:* Contractor shall also submit Samples to Engineer for review and approval in accordance with the acceptable schedule of Shop Drawings and Sample submittals.

a. Submit number of Samples specified in the Specifications.

b. Clearly identify each Sample as to material, Supplier, pertinent data such as catalog numbers, the use for which intended and other data as Engineer may require to enable Engineer to review the submittal for the limited purposes required by Paragraph 6.17.D.

B. Where a Shop Drawing or Sample is required by the Contract Documents or the Schedule of Submittals , any related Work performed prior to Engineer's review and approval of the pertinent submittal will be at the sole expense and responsibility of Contractor.

C. Submittal Procedures

1. Before submitting each Shop Drawing or Sample, Contractor shall have determined and verified:

a. all field measurements, quantities, dimensions, specified performance and design criteria, installation requirements, materials, catalog numbers, and similar information with respect thereto;

b. the suitability of all materials with respect to intended use, fabrication, shipping, handling, storage, assembly, and installation pertaining to the performance of the Work;

c. all information relative to Contractor's responsibilities for means, methods, techniques, sequences, and procedures of construction, and safety precautions and programs incident thereto; and

d. shall also have reviewed and coordinated each Shop Drawing or Sample with other Shop Drawings and Samples and with the requirements of the Work and the Contract Documents.

2. Each submittal shall bear a stamp or specific written certification that Contractor has satisfied Contractor's obligations under the Contract Documents

with respect to Contractor's review and approval of that submittal.

3. With each submittal, Contractor shall give Engineer specific written notice of any variations, that the Shop Drawing or Sample may have from the requirements of the Contract Documents. This notice shall be both a written communication separate from the Shop Drawing's or Sample Submittal; and, in addition, by a specific notation made on each Shop Drawing or Sample submitted to Engineer for review and approval of each such variation.

D. Engineer's Review

1. Engineer will provide timely review of Shop Drawings and Samples in accordance with the Schedule of Submittals acceptable to Engineer. Engineer's review and approval will be only to determine if the items covered by the submittals will, after installation or incorporation in the Work, conform to the information given in the Contract Documents and be compatible with the design concept of the completed Project as a functioning whole as indicated by the Contract Documents.

2. Engineer's review and approval will not extend to means, methods, techniques, sequences, or procedures of construction (except where a particular means, method, technique, sequence, or procedure of construction is specifically and expressly called for by the Contract Documents) or to safety precautions or programs incident thereto. The review and approval of a separate item as such will not indicate approval of the assembly in which the item functions.

3. Engineer's review and approval shall not relieve Contractor from responsibility for any variation from the requirements of the Contract Documents unless Contractor has complied with the requirements of Paragraph 6.17.C.3 and Engineer has given written approval of each such variation by specific written notation thereof incorporated in or accompanying the Shop Drawing or Sample. Engineer's review and approval shall not relieve Contractor from responsibility for complying with the requirements of Paragraph 6.17.C.1.

E. Resubmittal Procedures

1. Contractor shall make corrections required by Engineer and shall return the required number of corrected copies of Shop Drawings and submit, as required, new Samples for review and approval. Contractor shall direct specific attention in writing to revisions other than the corrections called for by Engineer on previous submittals.

6.18 Continuing the Work

A. Contractor shall carry on the Work and adhere to the Progress Schedule during all disputes or

disagreements with Owner. No Work shall be delayed or postponed pending resolution of any disputes or disagreements, except as permitted by Paragraph 15.04 or as Owner and Contractor may otherwise agree in writing.

6.19 Contractor's General Warranty and Guarantee

A. Contractor warrants and guarantees to Owner that all Work will be in accordance with the Contract Documents and will not be defective. Engineer and its Related Entities shall be entitled to rely on representation of Contractor's warranty and guarantee.

B. Contractor's warranty and guarantee hereunder excludes defects or damage caused by:

1. abuse, modification, or improper maintenance or operation by persons other than Contractor, Subcontractors, Suppliers, or any other individual or entity for whom Contractor is responsible; or

2. normal wear and tear under normal usage.

C. Contractor's obligation to perform and complete the Work in accordance with the Contract Documents shall be absolute. None of the following will constitute an acceptance of Work that is not in accordance with the Contract Documents or a release of Contractor's obligation to perform the Work in accordance with the Contract Documents:

1. observations by Engineer;

2. recommendation by Engineer or payment by Owner of any progress or final payment;

3. the issuance of a certificate of Substantial Completion by Engineer or any payment related thereto by Owner;

4. use or occupancy of the Work or any part thereof by Owner;

5. any review and approval of a Shop Drawing or Sample submittal or the issuance of a notice of acceptability by Engineer;

6. any inspection, test, or approval by others; or

7. any correction of defective Work by Owner.

6.20 Indemnification

A. To the fullest extent permitted by Laws and Regulations, Contractor shall indemnify and hold harmless Owner and Engineer, and the officers, directors, partners, employees, agents, consultants and subcontractors of each and any of them from and against all claims, costs, losses, and damages (including but not limited to all fees and charges of engineers, architects, attorneys, and other professionals and all court or

arbitration or other dispute resolution costs) arising out of or relating to the performance of the Work, provided that any such claim, cost, loss, or damage is attributable to bodily injury, sickness, disease, or death, or to injury to or destruction of tangible property (other than the Work itself), including the loss of use resulting therefrom but only to the extent caused by any negligent act or omission of Contractor, any Subcontractor, any Supplier, or any individual or entity directly or indirectly employed by any of them to perform any of the Work or anyone for whose acts any of them may be liable .

B. In any and all claims against Owner or Engineer or any of their respective consultants, agents, officers, directors, partners, or employees by any employee (or the survivor or personal representative of such employee) of Contractor, any Subcontractor, any Supplier, or any individual or entity directly or indirectly employed by any of them to perform any of the Work, or anyone for whose acts any of them may be liable, the indemnification obligation under Paragraph 6.20.A shall not be limited in any way by any limitation on the amount or type of damages, compensation, or benefits payable by or for Contractor or any such Subcontractor, Supplier, or other individual or entity under workers' compensation acts, disability benefit acts, or other employee benefit acts.

C. The indemnification obligations of Contractor under Paragraph 6.20.A shall not extend to the liability of Engineer and Engineer's officers, directors, partners, employees, agents, consultants and subcontractors arising out of:

1. the preparation or approval of, or the failure to prepare or approve, maps, Drawings, opinions, reports, surveys, Change Orders, designs, or Specifications; or
2. giving directions or instructions, or failing to give them, if that is the primary cause of the injury or damage.

6.21 *Delegation of Professional Design Services*

A. Contractor will not be required to provide professional design services unless such services are specifically required by the Contract Documents for a portion of the Work or unless such services are required to carry out Contractor's responsibilities for construction means, methods, techniques, sequences and procedures. Contractor shall not be required to provide professional services in violation of applicable law.

B. If professional design services or certifications by a design professional related to systems, materials or equipment are specifically required of Contractor by the Contract Documents, Owner and Engineer will specify all performance and design criteria that such services must satisfy. Contractor shall cause such services or certifications to be provided by a properly licensed professional, whose signature and seal

shall appear on all drawings, calculations, specifications, certifications, Shop Drawings and other submittals prepared by such professional. Shop Drawings and other submittals related to the Work designed or certified by such professional, if prepared by others, shall bear such professional's written approval when submitted to Engineer.

C. Owner and Engineer shall be entitled to rely upon the adequacy, accuracy and completeness of the services, certifications or approvals performed by such design professionals, provided Owner and Engineer have specified to Contractor all performance and design criteria that such services must satisfy.

D. Pursuant to this Paragraph 6.21, Engineer's review and approval of design calculations and design drawings will be only for the limited purpose of checking for conformance with performance and design criteria given and the design concept expressed in the Contract Documents. Engineer's review and approval of Shop Drawings and other submittals (except design calculations and design drawings) will be only for the purpose stated in Paragraph 6.17.D.1.

E. Contractor shall not be responsible for the adequacy of the performance or design criteria required by the Contract Documents.

ARTICLE 7 - OTHER WORK AT THE SITE

7.01 *Related Work at Site*

A. Owner may perform other work related to the Project at the Site with Owner's employees, or via other direct contracts therefor, or have other work performed by utility owners. If such other work is not noted in the Contract Documents, then:

1. written notice thereof will be given to Contractor prior to starting any such other work; and

2. if Owner and Contractor are unable to agree on entitlement to or on the amount or extent, if any, of any adjustment in the Contract Price or Contract Times that should be allowed as a result of such other work, a Claim may be made therefor as provided in Paragraph 10.05.

B. Contractor shall afford each other contractor who is a party to such a direct contract, each utility owner and Owner, if Owner is performing other work with Owner's employees, proper and safe access to the Site, a reasonable opportunity for the introduction and storage of materials and equipment and the execution of such other work, and shall properly coordinate the Work with theirs. Contractor shall do all cutting, fitting, and patching of the Work that may be required to properly connect or otherwise make its several parts come together and

properly integrate with such other work. Contractor shall not endanger any work of others by cutting, excavating, or otherwise altering their work and will only cut or alter their work with the written consent of Engineer and the others whose work will be affected. The duties and responsibilities of Contractor under this Paragraph are for the benefit of such utility owners and other contractors to the extent that there are comparable provisions for the benefit of Contractor in said direct contracts between Owner and such utility owners and other contractors.

C. If the proper execution or results of any part of Contractor's Work depends upon work performed by others under this Article 7, Contractor shall inspect such other work and promptly report to Engineer in writing any delays, defects, or deficiencies in such other work that render it unavailable or unsuitable for the proper execution and results of Contractor's Work. Contractor's failure to so report will constitute an acceptance of such other work as fit and proper for integration with Contractor's Work except for latent defects and deficiencies in such other work.

7.02 *Coordination*

A. If Owner intends to contract with others for the performance of other work on the Project at the Site, the following will be set forth in Supplementary Conditions:

1. the individual or entity who will have authority and responsibility for coordination of the activities among the various contractors will be identified;
2. the specific matters to be covered by such authority and responsibility will be itemized; and
3. the extent of such authority and responsibilities will be provided.

B. Unless otherwise provided in the Supplementary Conditions, Owner shall have sole authority and responsibility for such coordination.

7.03 *Legal Relationships*

A. Paragraphs 7.01.A and 7.02 are not applicable for utilities not under the control of Owner.

B. Each other direct contract of Owner under Paragraph 7.01.A shall provide that the other contractor is liable to Owner and Contractor for the reasonable direct delay and disruption costs incurred by Contractor as a result of the other contractor's actions or inactions.

C. Contractor shall be liable to Owner and any other contractor for the reasonable direct delay and disruption costs incurred by such other contractor as a result of Contractor's action or inactions.

ARTICLE 8 - OWNER'S RESPONSIBILITIES

8.01 *Communications to Contractor*

A. Except as otherwise provided in these General Conditions, Owner shall issue all communications to Contractor through Engineer.

8.02 *Replacement of Engineer*

A. In case of termination of the employment of Engineer, Owner shall appoint an engineer to whom Contractor makes no reasonable objection, whose status under the Contract Documents shall be that of the former Engineer.

8.03 *Furnish Data*

A. Owner shall promptly furnish the data required of Owner under the Contract Documents.

8.04 *Pay When Due*

A. Owner shall make payments to Contractor when they are due as provided in Paragraphs 14.02.C and 14.07.C.

8.05 *Lands and Easements; Reports and Tests*

A. Owner's duties in respect of providing lands and easements and providing engineering surveys to establish reference points are set forth in Paragraphs 4.01 and 4.05. Paragraph 4.02 refers to Owner's identifying and making available to Contractor copies of reports of explorations and tests of subsurface conditions and drawings of physical conditions in or relating to existing surface or subsurface structures at or contiguous to the Site that have been utilized by Engineer in preparing the Contract Documents.

8.06 *Insurance*

A. Owner's responsibilities, if any, in respect to purchasing and maintaining liability and property insurance are set forth in Article 5.

8.07 *Change Orders*

A. Owner is obligated to execute Change Orders as indicated in Paragraph 10.03.

8.08 *Inspections, Tests, and Approvals*

A. Owner's responsibility in respect to certain inspections, tests, and approvals is set forth in Paragraph 13.03.B.

8.09 *Limitations on Owner's Responsibilities*

A. The Owner shall not supervise, direct, or have control or authority over, nor be responsible for, Contractor's means, methods, techniques, sequences, or procedures of construction, or the safety precautions and programs incident thereto, or for any failure of Contractor to comply with Laws and Regulations applicable to the performance of the Work. Owner will not be responsible for Contractor's failure to perform the Work in accordance with the Contract Documents.

8.10 *Undisclosed Hazardous Environmental Condition*

A. Owner's responsibility in respect to an undisclosed Hazardous Environmental Condition is set forth in Paragraph 4.06.

8.11 *Evidence of Financial Arrangements*

A. If and to the extent Owner has agreed to furnish Contractor reasonable evidence that financial arrangements have been made to satisfy Owner's obligations under the Contract Documents, Owner's responsibility in respect thereof will be as set forth in the Supplementary Conditions.

ARTICLE 9 - ENGINEER'S STATUS DURING CONSTRUCTION

9.01 *Owner's Representative*

A. Engineer will be Owner's representative during the construction period. The duties and responsibilities and the limitations of authority of Engineer as Owner's representative during construction are set forth in the Contract Documents and will not be changed without written consent of Owner and Engineer.

9.02 *Visits to Site*

A. Engineer will make visits to the Site at intervals appropriate to the various stages of construction as Engineer deems necessary in order to observe as an experienced and qualified design professional the progress that has been made and the quality of the various aspects of Contractor's executed Work. Based on information obtained during such visits and observations, Engineer, for the benefit of Owner, will determine, in general, if the Work is proceeding in accordance with the Contract Documents. Engineer will not be required to make exhaustive or continuous inspections on the Site to check the quality or quantity of the Work. Engineer's efforts will be directed toward providing for Owner a greater degree of confidence that the completed Work will conform generally to the Contract Documents. On the basis of such visits and observations, Engineer will keep

Owner informed of the progress of the Work and will endeavor to guard Owner against defective Work.

B. Engineer's visits and observations are subject to all the limitations on Engineer's authority and responsibility set forth in Paragraph 9.09. Particularly, but without limitation, during or as a result of Engineer's visits or observations of Contractor's Work Engineer will not supervise, direct, control, or have authority over or be responsible for Contractor's means, methods, techniques, sequences, or procedures of construction, or the safety precautions and programs incident thereto, or for any failure of Contractor to comply with Laws and Regulations applicable to the performance of the Work.

9.03 *Project Representative*

A. If Owner and Engineer agree, Engineer will furnish a Resident Project Representative to assist Engineer in providing more extensive observation of the Work. The authority and responsibilities of any such Resident Project Representative and assistants will be as provided in the Supplementary Conditions, and limitations on the responsibilities thereof will be as provided in Paragraph 9.09. If Owner designates another representative or agent to represent Owner at the Site who is not Engineer's consultant, agent or employee, the responsibilities and authority and limitations thereon of such other individual or entity will be as provided in the Supplementary Conditions.

9.04 *Authorized Variations in Work*

A. Engineer may authorize minor variations in the Work from the requirements of the Contract Documents which do not involve an adjustment in the Contract Price or the Contract Times and are compatible with the design concept of the completed Project as a functioning whole as indicated by the Contract Documents. These may be accomplished by a Field Order and will be binding on Owner and also on Contractor, who shall perform the Work involved promptly. If Owner or Contractor believes that a Field Order justifies an adjustment in the Contract Price or Contract Times, or both, and the parties are unable to agree on entitlement to or on the amount or extent, if any, of any such adjustment, a Claim may be made therefor as provided in Paragraph 10.05.

9.05 *Rejecting Defective Work*

A. Engineer will have authority to reject Work which Engineer believes to be defective, or that Engineer believes will not produce a completed Project that conforms to the Contract Documents or that will prejudice the integrity of the design concept of the completed Project as a functioning whole as indicated by the Contract Documents. Engineer will also have authority to require special inspection or testing of the Work as provided in Paragraph 13.04, whether or not the Work is fabricated, installed, or completed.

9.06 *Shop Drawings, Change Orders and Payments*

A. In connection with Engineer's authority, and limitations thereof, as to Shop Drawings and Samples, see Paragraph 6.17.

B. In connection with Engineer's authority, and limitations thereof, as to design calculations and design drawings submitted in response to a delegation of professional design services, if any, see Paragraph 6.21.

C. In connection with Engineer's authority as to Change Orders, see Articles 10, 11, and 12.

D. In connection with Engineer's authority as to Applications for Payment, see Article 14.

9.07 *Determinations for Unit Price Work*

A. Engineer will determine the actual quantities and classifications of Unit Price Work performed by Contractor. Engineer will review with Contractor the Engineer's preliminary determinations on such matters before rendering a written decision thereon (by recommendation of an Application for Payment or otherwise). Engineer's written decision thereon will be final and binding (except as modified by Engineer to reflect changed factual conditions or more accurate data) upon Owner and Contractor, subject to the provisions of Paragraph 10.05.

9.08 *Decisions on Requirements of Contract Documents and Acceptability of Work*

A. Engineer will be the initial interpreter of the requirements of the Contract Documents and judge of the acceptability of the Work thereunder. All matters in question and other matters between Owner and Contractor arising prior to the date final payment is due relating to the acceptability of the Work, and the interpretation of the requirements of the Contract Documents pertaining to the performance of the Work, will be referred initially to Engineer in writing within 30 days of the event giving rise to the question

B. Engineer will, with reasonable promptness, render a written decision on the issue referred. If Owner or Contractor believe that any such decision entitles them to an adjustment in the Contract Price or Contract Times or both, a Claim may be made under Paragraph 10.05. The date of Engineer's decision shall be the date of the event giving rise to the issues referenced for the purposes of Paragraph 10.05.B.

C. Engineer's written decision on the issue referred will be final and binding on Owner and Contractor, subject to the provisions of Paragraph 10.05.

D. When functioning as interpreter and judge under this Paragraph 9.08, Engineer will not show

partiality to Owner or Contractor and will not be liable in connection with any interpretation or decision rendered in good faith in such capacity.

9.09 *Limitations on Engineer's Authority and Responsibilities*

A. Neither Engineer's authority or responsibility under this Article 9 or under any other provision of the Contract Documents nor any decision made by Engineer in good faith either to exercise or not exercise such authority or responsibility or the undertaking, exercise, or performance of any authority or responsibility by Engineer shall create, impose, or give rise to any duty in contract, tort, or otherwise owed by Engineer to Contractor, any Subcontractor, any Supplier, any other individual or entity, or to any surety for or employee or agent of any of them.

B. Engineer will not supervise, direct, control, or have authority over or be responsible for Contractor's means, methods, techniques, sequences, or procedures of construction, or the safety precautions and programs incident thereto, or for any failure of Contractor to comply with Laws and Regulations applicable to the performance of the Work. Engineer will not be responsible for Contractor's failure to perform the Work in accordance with the Contract Documents.

C. Engineer will not be responsible for the acts or omissions of Contractor or of any Subcontractor, any Supplier, or of any other individual or entity performing any of the Work.

D. Engineer's review of the final Application for Payment and accompanying documentation and all maintenance and operating instructions, schedules, guarantees, bonds, certificates of inspection, tests and approvals, and other documentation required to be delivered by Paragraph 14.07.A will only be to determine generally that their content complies with the requirements of, and in the case of certificates of inspections, tests, and approvals that the results certified indicate compliance with the Contract Documents.

E. The limitations upon authority and responsibility set forth in this Paragraph 9.09 shall also apply to, the Resident Project Representative, if any, and assistants, if any.

ARTICLE 10 - CHANGES IN THE WORK; CLAIMS

10.01 *Authorized Changes in the Work*

A. Without invalidating the Contract and without notice to any surety, Owner may, at any time or from time to time, order additions, deletions, or revisions in the Work by a Change Order, or a Work Change Directive. Upon receipt of any such document, Contractor shall

promptly proceed with the Work involved which will be performed under the applicable conditions of the Contract Documents (except as otherwise specifically provided).

B. If Owner and Contractor are unable to agree on entitlement to, or on the amount or extent, if any, of an adjustment in the Contract Price or Contract Times, or both, that should be allowed as a result of a Work Change Directive, a Claim may be made therefor as provided in Paragraph 10.05.

10.02 *Unauthorized Changes in the Work*

A. Contractor shall not be entitled to an increase in the Contract Price or an extension of the Contract Times with respect to any work performed that is not required by the Contract Documents as amended, modified, or supplemented as provided in Paragraph 3.04, except in the case of an emergency as provided in Paragraph 6.16 or in the case of uncovering Work as provided in Paragraph 13.04.B.

10.03 *Execution of Change Orders*

A. Owner and Contractor shall execute appropriate Change Orders recommended by Engineer covering:

1. changes in the Work which are: (i) ordered by Owner pursuant to Paragraph 10.01.A, (ii) required because of acceptance of defective Work under Paragraph 13.08.A or Owner's correction of defective Work under Paragraph 13.09, or (iii) agreed to by the parties;

2. changes in the Contract Price or Contract Times which are agreed to by the parties, including any undisputed sum or amount of time for Work actually performed in accordance with a Work Change Directive; and

3. changes in the Contract Price or Contract Times which embody the substance of any written decision rendered by Engineer pursuant to Paragraph 10.05; provided that, in lieu of executing any such Change Order, an appeal may be taken from any such decision in accordance with the provisions of the Contract Documents and applicable Laws and Regulations, but during any such appeal, Contractor shall carry on the Work and adhere to the Progress Schedule as provided in Paragraph 6.18.A.

10.04 *Notification to Surety*

A. If notice of any change affecting the general scope of the Work or the provisions of the Contract Documents (including, but not limited to, Contract Price or Contract Times) is required by the provisions of any bond to be given to a surety, the giving of any such notice will be Contractor's responsibility. The amount of each applicable bond will be adjusted to reflect the effect of any such change.

10.05 *Claims*

A. *Engineer's Decision Required:* All Claims, except those waived pursuant to Paragraph 14.09, shall be referred to the Engineer for decision. A decision by Engineer shall be required as a condition precedent to any exercise by Owner or Contractor of any rights or remedies either may otherwise have under the Contract Documents or by Laws and Regulations in respect of such Claims.

B. *Notice:* Written notice stating the general nature of each Claim, shall be delivered by the claimant to Engineer and the other party to the Contract promptly (but in no event later than 30 days) after the start of the event giving rise thereto. The responsibility to substantiate a Claim shall rest with the party making the Claim. Notice of the amount or extent of the Claim, with supporting data shall be delivered to the Engineer and the other party to the Contract within 60 days after the start of such event (unless Engineer allows additional time for claimant to submit additional or more accurate data in support of such Claim). A Claim for an adjustment in Contract Price shall be prepared in accordance with the provisions of Paragraph 12.01.B. A Claim for an adjustment in Contract Time shall be prepared in accordance with the provisions of Paragraph 12.02.B. Each Claim shall be accompanied by claimant's written statement that the adjustment claimed is the entire adjustment to which the claimant believes it is entitled as a result of said event. The opposing party shall submit any response to Engineer and the claimant within 30 days after receipt of the claimant's last submittal (unless Engineer allows additional time).

C. *Engineer's Action:* Engineer will review each Claim and, within 30 days after receipt of the last submittal of the claimant or the last submittal of the opposing party, if any, take one of the following actions in writing:

1. deny the Claim in whole or in part,

2. approve the Claim, or

3. notify the parties that the Engineer is unable to resolve the Claim if, in the Engineer's sole discretion, it would be inappropriate for the Engineer to do so. For purposes of further resolution of the Claim, such notice shall be deemed a denial.

D. In the event that Engineer does not take action on a Claim within said 30 days, the Claim shall be deemed denied.

E. Engineer's written action under Paragraph 10.05.C or denial pursuant to Paragraphs 10.05.C.3 or 10.05.D will be final and binding upon Owner and Contractor, unless Owner or Contractor invoke the dispute resolution procedure set forth in Article 16 within 30 days of such action or denial.

F. No Claim for an adjustment in Contract Price or Contract Times will be valid if not submitted in accordance with this Paragraph 10.05.

ARTICLE 11 - COST OF THE WORK;
ALLOWANCES; UNIT PRICE WORK

11.01 *Cost of the Work*

A. *Costs Included:* The term Cost of the Work means the sum of all costs, except those excluded in Paragraph 11.01.B, necessarily incurred and paid by Contractor in the proper performance of the Work. When the value of any Work covered by a Change Order or when a Claim for an adjustment in Contract Price is determined on the basis of Cost of the Work, the costs to be reimbursed to Contractor will be only those additional or incremental costs required because of the change in the Work or because of the event giving rise to the Claim. Except as otherwise may be agreed to in writing by Owner, such costs shall be in amounts no higher than those prevailing in the locality of the Project, shall include only the following items, and shall not include any of the costs itemized in Paragraph 11.01.B.

1. Payroll costs for employees in the direct employ of Contractor in the performance of the Work under schedules of job classifications agreed upon by Owner and Contractor. Such employees shall include, without limitation, superintendents, foremen, and other personnel employed full time at the Site. Payroll costs for employees not employed full time on the Work shall be apportioned on the basis of their time spent on the Work. Payroll costs shall include, but not be limited to, salaries and wages plus the cost of fringe benefits, which shall include social security contributions, unemployment, excise, and payroll taxes, workers' compensation, health and retirement benefits, bonuses, sick leave, vacation and holiday pay applicable thereto. The expenses of performing Work outside of regular working hours, on Saturday, Sunday, or legal holidays, shall be included in the above to the extent authorized by Owner.

2. Cost of all materials and equipment furnished and incorporated in the Work, including costs of transportation and storage thereof, and Suppliers' field services required in connection therewith. All cash discounts shall accrue to Contractor unless Owner deposits funds with Contractor with which to make payments, in which case the cash discounts shall accrue to Owner. All trade discounts, rebates and refunds and returns from sale of surplus materials and equipment shall accrue to Owner, and Contractor shall make provisions so that they may be obtained.

3. Payments made by Contractor to Subcontractors for Work performed by Subcontractors. If required by Owner, Contractor shall obtain competitive bids from subcontractors acceptable to Owner and

Contractor and shall deliver such bids to Owner, who will then determine, with the advice of Engineer, which bids, if any, will be acceptable. If any subcontract provides that the Subcontractor is to be paid on the basis of Cost of the Work plus a fee, the Subcontractor's Cost of the Work and fee shall be determined in the same manner as Contractor's Cost of the Work and fee as provided in this Paragraph 11.01.

4. Costs of special consultants (including but not limited to Engineers, architects, testing laboratories, surveyors, attorneys, and accountants) employed for services specifically related to the Work.

5. Supplemental costs including the following:

a. The proportion of necessary transportation, travel, and subsistence expenses of Contractor's employees incurred in discharge of duties connected with the Work.

b. Cost, including transportation and maintenance, of all materials, supplies, equipment, machinery, appliances, office, and temporary facilities at the Site, and hand tools not owned by the workers, which are consumed in the performance of the Work, and cost, less market value, of such items used but not consumed which remain the property of Contractor.

c. Rentals of all construction equipment and machinery, and the parts thereof whether rented from Contractor or others in accordance with rental agreements approved by Owner with the advice of Engineer, and the costs of transportation, loading, unloading, assembly, dismantling, and removal thereof. All such costs shall be in accordance with the terms of said rental agreements. The rental of any such equipment, machinery, or parts shall cease when the use thereof is no longer necessary for the Work.

d. Sales, consumer, use, and other similar taxes related to the Work, and for which Contractor is liable, imposed by Laws and Regulations.

e. Deposits lost for causes other than negligence of Contractor, any Subcontractor, or anyone directly or indirectly employed by any of them or for whose acts any of them may be liable, and royalty payments and fees for permits and licenses.

f. Losses and damages (and related expenses) caused by damage to the Work, not compensated by insurance or otherwise, sustained by Contractor in connection with the performance of the Work (except losses and damages within the deductible amounts of property insurance established in accordance with Paragraph 5.06.D), provided such losses and damages have

resulted from causes other than the negligence of Contractor, any Subcontractor, or anyone directly or indirectly employed by any of them or for whose acts any of them may be liable. Such losses shall include settlements made with the written consent and approval of Owner. No such losses, damages, and expenses shall be included in the Cost of the Work for the purpose of determining Contractor's fee.

g. The cost of utilities, fuel, and sanitary facilities at the Site.

h. Minor expenses such as telegrams, long distance telephone calls, telephone service at the Site, expresses, and similar petty cash items in connection with the Work.

i. The costs of premiums for all bonds and insurance Contractor is required by the Contract Documents to purchase and maintain.

B. Costs Excluded: The term Cost of the Work shall not include any of the following items:

1. Payroll costs and other compensation of Contractor's officers, executives, principals (of partnerships and sole proprietorships), general managers, safety managers, engineers, architects, estimators, attorneys, auditors, accountants, purchasing and contracting agents, expeditors, timekeepers, clerks, and other personnel employed by Contractor, whether at the Site or in Contractor's principal or branch office for general administration of the Work and not specifically included in the agreed upon schedule of job classifications referred to in Paragraph 11.01.A.1 or specifically covered by Paragraph 11.01.A.4, all of which are to be considered administrative costs covered by the Contractor's fee.

2. Expenses of Contractor's principal and branch offices other than Contractor's office at the Site.

3. Any part of Contractor's capital expenses, including interest on Contractor's capital employed for the Work and charges against Contractor for delinquent payments.

4. Costs due to the negligence of Contractor, any Subcontractor, or anyone directly or indirectly employed by any of them or for whose acts any of them may be liable, including but not limited to, the correction of defective Work, disposal of materials or equipment wrongly supplied, and making good any damage to property.

5. Other overhead or general expense costs of any kind and the costs of any item not specifically and expressly included in Paragraphs 11.01.A and 11.01.B.

C. Contractor's Fee: When all the Work is performed on the basis of cost-plus, Contractor's fee shall

be determined as set forth in the Agreement. When the value of any Work covered by a Change Order or when a Claim for an adjustment in Contract Price is determined on the basis of Cost of the Work, Contractor's fee shall be determined as set forth in Paragraph 12.01.C.

D. Documentation: Whenever the Cost of the Work for any purpose is to be determined pursuant to Paragraphs 11.01.A and 11.01.B, Contractor will establish and maintain records thereof in accordance with generally accepted accounting practices and submit in a form acceptable to Engineer an itemized cost breakdown together with supporting data.

11.02 Allowances

A. It is understood that Contractor has included in the Contract Price all allowances so named in the Contract Documents and shall cause the Work so covered to be performed for such sums and by such persons or entities as may be acceptable to Owner and Engineer.

B. Cash Allowances

1. Contractor agrees that:

a. the cash allowances include the cost to Contractor (less any applicable trade discounts) of materials and equipment required by the allowances to be delivered at the Site, and all applicable taxes; and

b. Contractor's costs for unloading and handling on the Site, labor, installation, overhead, profit, and other expenses contemplated for the cash allowances have been included in the Contract Price and not in the allowances, and no demand for additional payment on account of any of the foregoing will be valid.

C. Contingency Allowance

1. Contractor agrees that a contingency allowance, if any, is for the sole use of Owner to cover unanticipated costs.

D. Prior to final payment, an appropriate Change Order will be issued as recommended by Engineer to reflect actual amounts due Contractor on account of Work covered by allowances, and the Contract Price shall be correspondingly adjusted.

11.03 Unit Price Work

A. Where the Contract Documents provide that all or part of the Work is to be Unit Price Work, initially the Contract Price will be deemed to include for all Unit Price Work an amount equal to the sum of the unit price for each separately identified item of Unit Price Work times the estimated quantity of each item as indicated in the Agreement.

B. The estimated quantities of items of Unit Price Work are not guaranteed and are solely for the purpose of comparison of Bids and determining an initial Contract Price. Determinations of the actual quantities and classifications of Unit Price Work performed by Contractor will be made by Engineer subject to the provisions of Paragraph 9.07.

C. Each unit price will be deemed to include an amount considered by Contractor to be adequate to cover Contractor's overhead and profit for each separately identified item.

D. Owner or Contractor may make a Claim for an adjustment in the Contract Price in accordance with Paragraph 10.05 if:

1. the quantity of any item of Unit Price Work performed by Contractor differs materially and significantly from the estimated quantity of such item indicated in the Agreement; and

2. there is no corresponding adjustment with respect any other item of Work; and

3. Contractor believes that Contractor is entitled to an increase in Contract Price as a result of having incurred additional expense or Owner believes that Owner is entitled to a decrease in Contract Price and the parties are unable to agree as to the amount of any such increase or decrease.

ARTICLE 12 - CHANGE OF CONTRACT PRICE; CHANGE OF CONTRACT TIMES

12.01 *Change of Contract Price*

A. The Contract Price may only be changed by a Change Order. Any Claim for an adjustment in the Contract Price shall be based on written notice submitted by the party making the Claim to the Engineer and the other party to the Contract in accordance with the provisions of Paragraph 10.05.

B. The value of any Work covered by a Change Order or of any Claim for an adjustment in the Contract Price will be determined as follows:

1. where the Work involved is covered by unit prices contained in the Contract Documents, by application of such unit prices to the quantities of the items involved (subject to the provisions of Paragraph 11.03); or

2. where the Work involved is not covered by unit prices contained in the Contract Documents, by a mutually agreed lump sum (which may include an

allowance for overhead and profit not necessarily in accordance with Paragraph 12.01.C.2); or

3. where the Work involved is not covered by unit prices contained in the Contract Documents and agreement to a lump sum is not reached under Paragraph 12.01.B.2, on the basis of the Cost of the Work (determined as provided in Paragraph 11.01) plus a Contractor's fee for overhead and profit (determined as provided in Paragraph 12.01.C).

C. *Contractor's Fee:* The Contractor's fee for overhead and profit shall be determined as follows:

1. a mutually acceptable fixed fee; or

2. if a fixed fee is not agreed upon, then a fee based on the following percentages of the various portions of the Cost of the Work:

a. for costs incurred under Paragraphs 11.01.A.1 and 11.01.A.2, the Contractor's fee shall be 15 percent;

b. for costs incurred under Paragraph 11.01.A.3, the Contractor's fee shall be five percent;

c. where one or more tiers of subcontracts are on the basis of Cost of the Work plus a fee and no fixed fee is agreed upon, the intent of Paragraph 12.01.C.2.a is that the Subcontractor who actually performs the Work, at whatever tier, will be paid a fee of 15 percent of the costs incurred by such Subcontractor under Paragraphs 11.01.A.1 and 11.01.A.2 and that any higher tier Subcontractor and Contractor will each be paid a fee of five percent of the amount paid to the next lower tier Subcontractor;

d. no fee shall be payable on the basis of costs itemized under Paragraphs 11.01.A.4, 11.01.A.5, and 11.01.B;

e. the amount of credit to be allowed by Contractor to Owner for any change which results in a net decrease in cost will be the amount of the actual net decrease in cost plus a deduction in Contractor's fee by an amount equal to five percent of such net decrease; and

f. when both additions and credits are involved in any one change, the adjustment in Contractor's fee shall be computed on the basis of the net change in accordance with Paragraphs 12.01.C.2.a through 12.01.C.2.e, inclusive.

12.02 *Change of Contract Times*

A. The Contract Times may only be changed by a Change Order. Any Claim for an adjustment in the Contract Times shall be based on written notice submitted

by the party making the Claim to the Engineer and the other party to the Contract in accordance with the provisions of Paragraph 10.05.

B. Any adjustment of the Contract Times covered by a Change Order or any Claim for an adjustment in the Contract Times will be determined in accordance with the provisions of this Article 12.

12.03 *Delays*

A. Where Contractor is prevented from completing any part of the Work within the Contract Times due to delay beyond the control of Contractor, the Contract Times will be extended in an amount equal to the time lost due to such delay if a Claim is made therefor as provided in Paragraph 12.02.A. Delays beyond the control of Contractor shall include, but not be limited to, acts or neglect by Owner, acts or neglect of utility owners or other contractors performing other work as contemplated by Article 7, fires, floods, epidemics, abnormal weather conditions, or acts of God.

B. If Owner, Engineer, or other contractors or utility owners performing other work for Owner as contemplated by Article 7, or anyone for whom Owner is responsible, delays, disrupts, or interferes with the performance or progress of the Work, then Contractor shall be entitled to an equitable adjustment in the Contract Price or the Contract Times, or both. Contractor's entitlement to an adjustment of the Contract Times is conditioned on such adjustment being essential to Contractor's ability to complete the Work within the Contract Times.

C. If Contractor is delayed in the performance or progress of the Work by fire, flood, epidemic, abnormal weather conditions, acts of God, acts or failures to act of utility owners not under the control of Owner, or other causes not the fault of and beyond control of Owner and Contractor, then Contractor shall be entitled to an equitable adjustment in Contract Times, if such adjustment is essential to Contractor's ability to complete the Work within the Contract Times. Such an adjustment shall be Contractor's sole and exclusive remedy for the delays described in this Paragraph 12.03.C.

D. Owner, Engineer and the Related Entities of each of them shall not be liable to Contractor for any claims, costs, losses, or damages (including but not limited to all fees and charges of Engineers, architects, attorneys, and other professionals and all court or arbitration or other dispute resolution costs) sustained by Contractor on or in connection with any other project or anticipated project.

E. Contractor shall not be entitled to an adjustment in Contract Price or Contract Times for delays within the control of Contractor. Delays attributable to and within the control of a Subcontractor or Supplier shall be deemed to be delays within the control of Contractor.

ARTICLE 13 - TESTS AND INSPECTIONS; CORRECTION, REMOVAL OR ACCEPTANCE OF DEFECTIVE WORK

13.01 *Notice of Defects*

A. Prompt notice of all defective Work of which Owner or Engineer has actual knowledge will be given to Contractor. All defective Work may be rejected, corrected, or accepted as provided in this Article 13.

13.02 *Access to Work*

A. Owner, Engineer, their consultants and other representatives and personnel of Owner, independent testing laboratories, and governmental agencies with jurisdictional interests will have access to the Site and the Work at reasonable times for their observation, inspecting, and testing. Contractor shall provide them proper and safe conditions for such access and advise them of Contractor's Site safety procedures and programs so that they may comply therewith as applicable.

13.03 *Tests and Inspections*

A. Contractor shall give Engineer timely notice of readiness of the Work for all required inspections, tests, or approvals and shall cooperate with inspection and testing personnel to facilitate required inspections or tests.

B. Owner shall employ and pay for the services of an independent testing laboratory to perform all inspections, tests, or approvals required by the Contract Documents except:

1. for inspections, tests, or approvals covered by Paragraphs 13.03.C and 13.03.D below;
2. that costs incurred in connection with tests or inspections conducted pursuant to Paragraph 13.04.B shall be paid as provided in said Paragraph 13.04.C; and
3. as otherwise specifically provided in the Contract Documents.

C. If Laws or Regulations of any public body having jurisdiction require any Work (or part thereof) specifically to be inspected, tested, or approved by an employee or other representative of such public body, Contractor shall assume full responsibility for arranging and obtaining such inspections, tests, or approvals, pay all costs in connection therewith, and furnish Engineer the required certificates of inspection or approval.

D. Contractor shall be responsible for arranging and obtaining and shall pay all costs in connection with any inspections, tests, or approvals required for Owner's and Engineer's acceptance of materials or equipment to

be incorporated in the Work; or acceptance of materials, mix designs, or equipment submitted for approval prior to Contractor's purchase thereof for incorporation in the Work. Such inspections, tests, or approvals shall be performed by organizations acceptable to Owner and Engineer.

E. If any Work (or the work of others) that is to be inspected, tested, or approved is covered by Contractor without written concurrence of Engineer, it must, if requested by Engineer, be uncovered for observation.

F. Uncovering Work as provided in Paragraph 13.03.E shall be at Contractor's expense unless Contractor has given Engineer timely notice of Contractor's intention to cover the same and Engineer has not acted with reasonable promptness in response to such notice.

13.04 *Uncovering Work*

A. If any Work is covered contrary to the written request of Engineer, it must, if requested by Engineer, be uncovered for Engineer's observation and replaced at Contractor's expense.

B. If Engineer considers it necessary or advisable that covered Work be observed by Engineer or inspected or tested by others, Contractor, at Engineer's request, shall uncover, expose, or otherwise make available for observation, inspection, or testing as Engineer may require, that portion of the Work in question, furnishing all necessary labor, material, and equipment.

C. If it is found that the uncovered Work is defective, Contractor shall pay all claims, costs, losses, and damages (including but not limited to all fees and charges of engineers, architects, attorneys, and other professionals and all court or arbitration or other dispute resolution costs) arising out of or relating to such uncovering, exposure, observation, inspection, and testing, and of satisfactory replacement or reconstruction (including but not limited to all costs of repair or replacement of work of others); and Owner shall be entitled to an appropriate decrease in the Contract Price. If the parties are unable to agree as to the amount thereof, Owner may make a Claim therefor as provided in Paragraph 10.05.

D. If, the uncovered Work is not found to be defective, Contractor shall be allowed an increase in the Contract Price or an extension of the Contract Times, or both, directly attributable to such uncovering, exposure, observation, inspection, testing, replacement, and reconstruction. If the parties are unable to agree as to the amount or extent thereof, Contractor may make a Claim therefor as provided in Paragraph 10.05.

13.05 *Owner May Stop the Work*

A. If the Work is defective, or Contractor fails to supply sufficient skilled workers or suitable materials or equipment, or fails to perform the Work in such a way that the completed Work will conform to the Contract Documents, Owner may order Contractor to stop the Work, or any portion thereof, until the cause for such order has been eliminated; however, this right of Owner to stop the Work shall not give rise to any duty on the part of Owner to exercise this right for the benefit of Contractor, any Subcontractor, any Supplier, any other individual or entity, or any surety for, or employee or agent of any of them.

13.06 *Correction or Removal of Defective Work*

A. Promptly after receipt of notice, Contractor shall correct all defective Work, whether or not fabricated, installed, or completed, or, if the Work has been rejected by Engineer, remove it from the Project and replace it with Work that is not defective. Contractor shall pay all claims, costs, losses, and damages (including but not limited to all fees and charges of engineers, architects, attorneys, and other professionals and all court or arbitration or other dispute resolution costs) arising out of or relating to such correction or removal (including but not limited to all costs of repair or replacement of work of others).

B. When correcting defective Work under the terms of this Paragraph 13.06 or Paragraph 13.07, Contractor shall take no action that would void or otherwise impair Owner's special warranty and guarantee, if any, on said Work.

13.07 *Correction Period*

A. If within one year after the date of Substantial Completion (or such longer period of time as may be prescribed by the terms of any applicable special guarantee required by the Contract Documents) or by any specific provision of the Contract Documents, any Work is found to be defective, or if the repair of any damages to the land or areas made available for Contractor's use by Owner or permitted by Laws and Regulations as contemplated in Paragraph 6.11.A is found to be defective, Contractor shall promptly, without cost to Owner and in accordance with Owner's written instructions:

1. repair such defective land or areas; or
2. correct such defective Work; or
3. if the defective Work has been rejected by Owner, remove it from the Project and replace it with Work that is not defective, and
4. satisfactorily correct or repair or remove and replace any damage to other Work, to the work of others or other land or areas resulting therefrom.

B. If Contractor does not promptly comply with the terms of Owner's written instructions, or in an emergency where delay would cause serious risk of loss or damage, Owner may have the defective Work corrected or repaired or may have the rejected Work removed and replaced. All claims, costs, losses, and damages (including but not limited to all fees and charges of engineers, architects, attorneys, and other professionals and all court or arbitration or other dispute resolution costs) arising out of or relating to such correction or repair or such removal and replacement (including but not limited to all costs of repair or replacement of work of others) will be paid by Contractor.

C. In special circumstances where a particular item of equipment is placed in continuous service before Substantial Completion of all the Work, the correction period for that item may start to run from an earlier date if so provided in the Specifications .

D. Where defective Work (and damage to other Work resulting therefrom) has been corrected or removed and replaced under this Paragraph 13.07, the correction period hereunder with respect to such Work will be extended for an additional period of one year after such correction or removal and replacement has been satisfactorily completed.

E. Contractor's obligations under this Paragraph 13.07 are in addition to any other obligation or warranty. The provisions of this Paragraph 13.07 shall not be construed as a substitute for or a waiver of the provisions of any applicable statute of limitation or repose.

13.08 *Acceptance of Defective Work*

A. If, instead of requiring correction or removal and replacement of defective Work, Owner (and, prior to Engineer's recommendation of final payment, Engineer) prefers to accept it, Owner may do so. Contractor shall pay all claims, costs, losses, and damages (including but not limited to all fees and charges of engineers, architects, attorneys, and other professionals and all court or arbitration or other dispute resolution costs) attributable to Owner's evaluation of and determination to accept such defective Work (such costs to be approved by Engineer as to reasonableness) and the diminished value of the Work to the extent not otherwise paid by Contractor pursuant to this sentence. If any such acceptance occurs prior to Engineer's recommendation of final payment, a Change Order will be issued incorporating the necessary revisions in the Contract Documents with respect to the Work, and Owner shall be entitled to an appropriate decrease in the Contract Price, reflecting the diminished value of Work so accepted. If the parties are unable to agree as to the amount thereof, Owner may make a Claim therefor as provided in Paragraph 10.05. If the acceptance occurs after such recommendation, an appropriate amount will be paid by Contractor to Owner.

13.09 *Owner May Correct Defective Work*

A. If Contractor fails within a reasonable time after written notice from Engineer to correct defective Work or to remove and replace rejected Work as required by Engineer in accordance with Paragraph 13.06.A, or if Contractor fails to perform the Work in accordance with the Contract Documents, or if Contractor fails to comply with any other provision of the Contract Documents, Owner may, after seven days written notice to Contractor, correct or remedy any such deficiency.

B. In exercising the rights and remedies under this Paragraph 13.09, Owner shall proceed expeditiously. In connection with such corrective or remedial action, Owner may exclude Contractor from all or part of the Site, take possession of all or part of the Work and suspend Contractor's services related thereto, take possession of Contractor's tools, appliances, construction equipment and machinery at the Site, and incorporate in the Work all materials and equipment stored at the Site or for which Owner has paid Contractor but which are stored elsewhere. Contractor shall allow Owner, Owner's representatives, agents and employees, Owner's other contractors, and Engineer and Engineer's consultants access to the Site to enable Owner to exercise the rights and remedies under this Paragraph.

C. All claims, costs, losses, and damages (including but not limited to all fees and charges of engineers, architects, attorneys, and other professionals and all court or arbitration or other dispute resolution costs) incurred or sustained by Owner in exercising the rights and remedies under this Paragraph 13.09 will be charged against Contractor, and a Change Order will be issued incorporating the necessary revisions in the Contract Documents with respect to the Work; and Owner shall be entitled to an appropriate decrease in the Contract Price. If the parties are unable to agree as to the amount of the adjustment, Owner may make a Claim therefor as provided in Paragraph 10.05. Such claims, costs, losses and damages will include but not be limited to all costs of repair, or replacement of work of others destroyed or damaged by correction, removal, or replacement of Contractor's defective Work.

D. Contractor shall not be allowed an extension of the Contract Times because of any delay in the performance of the Work attributable to the exercise by Owner of Owner's rights and remedies under this Paragraph 13.09.

ARTICLE 14 - PAYMENTS TO CONTRACTOR AND COMPLETION

14.01 *Schedule of Values*

A. The Schedule of Values established as provided in Paragraph 2.07.A will serve as the basis for progress

payments and will be incorporated into a form of Application for Payment acceptable to Engineer. Progress payments on account of Unit Price Work will be based on the number of units completed.

14.02 *Progress Payments*

A. Applications for Payments

1. At least 20 days before the date established in the Agreement for each progress payment (but not more often than once a month), Contractor shall submit to Engineer for review an Application for Payment filled out and signed by Contractor covering the Work completed as of the date of the Application and accompanied by such supporting documentation as is required by the Contract Documents. If payment is requested on the basis of materials and equipment not incorporated in the Work but delivered and suitably stored at the Site or at another location agreed to in writing, the Application for Payment shall also be accompanied by a bill of sale, invoice, or other documentation warranting that Owner has received the materials and equipment free and clear of all Liens and evidence that the materials and equipment are covered by appropriate property insurance or other arrangements to protect Owner's interest therein, all of which must be satisfactory to Owner.

2. Beginning with the second Application for Payment, each Application shall include an affidavit of Contractor stating that all previous progress payments received on account of the Work have been applied on account to discharge Contractor's legitimate obligations associated with prior Applications for Payment.

3. The amount of retainage with respect to progress payments will be as stipulated in the Agreement.

B. *Review of Applications*

1. Engineer will, within 10 days after receipt of each Application for Payment, either indicate in writing a recommendation of payment and present the Application to Owner or return the Application to Contractor indicating in writing Engineer's reasons for refusing to recommend payment. In the latter case, Contractor may make the necessary corrections and resubmit the Application.

2. Engineer's recommendation of any payment requested in an Application for Payment will constitute a representation by Engineer to Owner, based on Engineer's observations on the Site of the executed Work as an experienced and qualified design professional and on Engineer's review of the Application for Payment and the accompanying data and schedules, that to the best of Engineer's knowledge, information and belief:

a. the Work has progressed to the point indicated;

b. the quality of the Work is generally in accordance with the Contract Documents (subject to an evaluation of the Work as a functioning whole prior to or upon Substantial Completion, to the results of any subsequent tests called for in the Contract Documents, to a final determination of quantities and classifications for Unit Price Work under Paragraph 9.07, and to any other qualifications stated in the recommendation); and

c. the conditions precedent to Contractor's being entitled to such payment appear to have been fulfilled in so far as it is Engineer's responsibility to observe the Work.

3. By recommending any such payment Engineer will not thereby be deemed to have represented that:

a. inspections made to check the quality or the quantity of the Work as it has been performed have been exhaustive, extended to every aspect of the Work in progress, or involved detailed inspections of the Work beyond the responsibilities specifically assigned to Engineer in the Contract Documents; or

b. that there may not be other matters or issues between the parties that might entitle Contractor to be paid additionally by Owner or entitle Owner to withhold payment to Contractor.

4. Neither Engineer's review of Contractor's Work for the purposes of recommending payments nor Engineer's recommendation of any payment, including final payment, will impose responsibility on Engineer:

a. to supervise, direct, or control the Work, or

b. for the means, methods, techniques, sequences, or procedures of construction, or the safety precautions and programs incident thereto, or

c. for Contractor's failure to comply with Laws and Regulations applicable to Contractor's performance of the Work, or

d. to make any examination to ascertain how or for what purposes Contractor has used the moneys paid on account of the Contract Price, or

e. to determine that title to any of the Work, materials, or equipment has passed to Owner free and clear of any Liens.

5. Engineer may refuse to recommend the whole or any part of any payment if, in Engineer's opinion, it would be incorrect to make the representations to Owner stated in Paragraph 14.02.B.2. Engineer may also refuse to recommend any such payment or, because of subsequently discovered evidence or the results of subsequent

inspections or tests, revise or revoke any such payment recommendation previously made, to such extent as may be necessary in Engineer's opinion to protect Owner from loss because:

- a. the Work is defective, or completed Work has been damaged, requiring correction or replacement;
- b. the Contract Price has been reduced by Change Orders;
- c. Owner has been required to correct defective Work or complete Work in accordance with Paragraph 13.09; or
- d. Engineer has actual knowledge of the occurrence of any of the events enumerated in Paragraph 15.02.A.

C. Payment Becomes Due

1. Ten days after presentation of the Application for Payment to Owner with Engineer's recommendation, the amount recommended will (subject to the provisions of Paragraph 14.02.D) become due, and when due will be paid by Owner to Contractor.

D. Reduction in Payment

1. Owner may refuse to make payment of the full amount recommended by Engineer because:

- a. claims have been made against Owner on account of Contractor's performance or furnishing of the Work;
- b. Liens have been filed in connection with the Work, except where Contractor has delivered a specific bond satisfactory to Owner to secure the satisfaction and discharge of such Liens;
- c. there are other items entitling Owner to a set-off against the amount recommended; or
- d. Owner has actual knowledge of the occurrence of any of the events enumerated in Paragraphs 14.02.B.5.a through 14.02.B.5.c or Paragraph 15.02.A.

2. If Owner refuses to make payment of the full amount recommended by Engineer, Owner will give Contractor immediate written notice (with a copy to Engineer) stating the reasons for such action and promptly pay Contractor any amount remaining after deduction of the amount so withheld. Owner shall promptly pay Contractor the amount so withheld, or any adjustment thereto agreed to by Owner and Contractor, when Contractor corrects to Owner's satisfaction the reasons for such action.

3. If it is subsequently determined that Owner's refusal of payment was not justified, the amount wrongfully withheld shall be treated as an amount due as determined by Paragraph 14.02.C.1.

14.03 *Contractor's Warranty of Title*

A. Contractor warrants and guarantees that title to all Work, materials, and equipment covered by any Application for Payment, whether incorporated in the Project or not, will pass to Owner no later than the time of payment free and clear of all Liens.

14.04 *Substantial Completion*

A. When Contractor considers the entire Work ready for its intended use Contractor shall notify Owner and Engineer in writing that the entire Work is substantially complete (except for items specifically listed by Contractor as incomplete) and request that Engineer issue a certificate of Substantial Completion.

B. Promptly after Contractor's notification, , Owner, Contractor, and Engineer shall make an inspection of the Work to determine the status of completion. If Engineer does not consider the Work substantially complete, Engineer will notify Contractor in writing giving the reasons therefor.

C. If Engineer considers the Work substantially complete, Engineer will deliver to Owner a tentative certificate of Substantial Completion which shall fix the date of Substantial Completion. There shall be attached to the certificate a tentative list of items to be completed or corrected before final payment. Owner shall have seven days after receipt of the tentative certificate during which to make written objection to Engineer as to any provisions of the certificate or attached list. If, after considering such objections, Engineer concludes that the Work is not substantially complete, Engineer will within 14 days after submission of the tentative certificate to Owner notify Contractor in writing, stating the reasons therefor. If, after consideration of Owner's objections, Engineer considers the Work substantially complete, Engineer will within said 14 days execute and deliver to Owner and Contractor a definitive certificate of Substantial Completion (with a revised tentative list of items to be completed or corrected) reflecting such changes from the tentative certificate as Engineer believes justified after consideration of any objections from Owner.

D. At the time of delivery of the tentative certificate of Substantial Completion, Engineer will deliver to Owner and Contractor a written recommendation as to division of responsibilities pending final payment between Owner and Contractor with respect to security, operation, safety, and protection of the Work, maintenance, heat, utilities, insurance, and warranties and guarantees. Unless Owner and Contractor agree otherwise in writing and so inform Engineer in writing prior to Engineer's issuing the definitive certificate of Substantial

Completion, Engineer's aforesaid recommendation will be binding on Owner and Contractor until final payment.

E. Owner shall have the right to exclude Contractor from the Site after the date of Substantial Completion subject to allowing Contractor reasonable access to complete or correct items on the tentative list.

14.05 *Partial Utilization*

A. Prior to Substantial Completion of all the Work, Owner may use or occupy any substantially completed part of the Work which has specifically been identified in the Contract Documents, or which Owner, Engineer, and Contractor agree constitutes a separately functioning and usable part of the Work that can be used by Owner for its intended purpose without significant interference with Contractor's performance of the remainder of the Work, subject to the following conditions.

1. Owner at any time may request Contractor in writing to permit Owner to use or occupy any such part of the Work which Owner believes to be ready for its intended use and substantially complete. If and when Contractor agrees that such part of the Work is substantially complete, Contractor will certify to Owner and Engineer that such part of the Work is substantially complete and request Engineer to issue a certificate of Substantial Completion for that part of the Work.

2. Contractor at any time may notify Owner and Engineer in writing that Contractor considers any such part of the Work ready for its intended use and substantially complete and request Engineer to issue a certificate of Substantial Completion for that part of the Work.

3. Within a reasonable time after either such request, Owner, Contractor, and Engineer shall make an inspection of that part of the Work to determine its status of completion. If Engineer does not consider that part of the Work to be substantially complete, Engineer will notify Owner and Contractor in writing giving the reasons therefor. If Engineer considers that part of the Work to be substantially complete, the provisions of Paragraph 14.04 will apply with respect to certification of Substantial Completion of that part of the Work and the division of responsibility in respect thereof and access thereto.

4. No use or occupancy or separate operation of part of the Work may occur prior to compliance with the requirements of Paragraph 5.10 regarding property insurance.

14.06 *Final Inspection*

A. Upon written notice from Contractor that the entire Work or an agreed portion thereof is complete, Engineer will promptly make a final inspection with Owner and Contractor and will notify Contractor in writing of all particulars in which this inspection reveals

that the Work is incomplete or defective. Contractor shall immediately take such measures as are necessary to complete such Work or remedy such deficiencies.

14.07 *Final Payment*

A. Application for Payment

1. After Contractor has, in the opinion of Engineer, satisfactorily completed all corrections identified during the final inspection and has delivered, in accordance with the Contract Documents, all maintenance and operating instructions, schedules, guarantees, bonds, certificates or other evidence of insurance certificates of inspection, marked-up record documents (as provided in Paragraph 6.12), and other documents, Contractor may make application for final payment following the procedure for progress payments.

2. The final Application for Payment shall be accompanied (except as previously delivered) by:

- a. all documentation called for in the Contract Documents, including but not limited to the evidence of insurance required by Paragraph 5.04.B.7;
- b. consent of the surety, if any, to final payment;
- c. a list of all Claims against Owner that Contractor believes are unsettled; and
- d. complete and legally effective releases or waivers (satisfactory to Owner) of all Lien rights arising out of or Liens filed in connection with the Work.

3. In lieu of the releases or waivers of Liens specified in Paragraph 14.07.A.2 and as approved by Owner, Contractor may furnish receipts or releases in full and an affidavit of Contractor that: (i) the releases and receipts include all labor, services, material, and equipment for which a Lien could be filed; and (ii) all payrolls, material and equipment bills, and other indebtedness connected with the Work for which Owner or Owner's property might in any way be responsible have been paid or otherwise satisfied. If any Subcontractor or Supplier fails to furnish such a release or receipt in full, Contractor may furnish a bond or other collateral satisfactory to Owner to indemnify Owner against any Lien.

B. *Engineer's Review of Application and Acceptance*

1. If, on the basis of Engineer's observation of the Work during construction and final inspection, and Engineer's review of the final Application for Payment and accompanying documentation as required by the Contract Documents, Engineer is satisfied that the Work has been completed and Contractor's other obligations

under the Contract Documents have been fulfilled, Engineer will, within ten days after receipt of the final Application for Payment, indicate in writing Engineer's recommendation of payment and present the Application for Payment to Owner for payment. At the same time Engineer will also give written notice to Owner and Contractor that the Work is acceptable subject to the provisions of Paragraph 14.09. Otherwise, Engineer will return the Application for Payment to Contractor, indicating in writing the reasons for refusing to recommend final payment, in which case Contractor shall make the necessary corrections and resubmit the Application for Payment.

C. Payment Becomes Due

1. Thirty days after the presentation to Owner of the Application for Payment and accompanying documentation, the amount recommended by Engineer, less any sum Owner is entitled to set off against Engineer's recommendation, including but not limited to liquidated damages, will become due and , will be paid by Owner to Contractor.

14.08 *Final Completion Delayed*

A. If, through no fault of Contractor, final completion of the Work is significantly delayed, and if Engineer so confirms, Owner shall, upon receipt of Contractor's final Application for Payment (for Work fully completed and accepted) and recommendation of Engineer, and without terminating the Contract, make payment of the balance due for that portion of the Work fully completed and accepted. If the remaining balance to be held by Owner for Work not fully completed or corrected is less than the retainage stipulated in the Agreement, and if bonds have been furnished as required in Paragraph 5.01, the written consent of the surety to the payment of the balance due for that portion of the Work fully completed and accepted shall be submitted by Contractor to Engineer with the Application for such payment. Such payment shall be made under the terms and conditions governing final payment, except that it shall not constitute a waiver of Claims.

14.09 *Waiver of Claims*

A. The making and acceptance of final payment will constitute:

1. a waiver of all Claims by Owner against Contractor, except Claims arising from unsettled Liens, from defective Work appearing after final inspection pursuant to Paragraph 14.06, from failure to comply with the Contract Documents or the terms of any special guarantees specified therein, or from Contractor's continuing obligations under the Contract Documents; and

2. a waiver of all Claims by Contractor against Owner other than those previously made in accordance

with the requirements herein and expressly acknowledged by Owner in writing as still unsettled.

ARTICLE 15 - SUSPENSION OF WORK AND TERMINATION

15.01 *Owner May Suspend Work*

A. At any time and without cause, Owner may suspend the Work or any portion thereof for a period of not more than 90 consecutive days by notice in writing to Contractor and Engineer which will fix the date on which Work will be resumed. Contractor shall resume the Work on the date so fixed. Contractor shall be granted an adjustment in the Contract Price or an extension of the Contract Times, or both, directly attributable to any such suspension if Contractor makes a Claim therefor as provided in Paragraph 10.05.

15.02 *Owner May Terminate for Cause*

A. The occurrence of any one or more of the following events will justify termination for cause:

1. Contractor's persistent failure to perform the Work in accordance with the Contract Documents (including, but not limited to, failure to supply sufficient skilled workers or suitable materials or equipment or failure to adhere to the Progress Schedule established under Paragraph 2.07 as adjusted from time to time pursuant to Paragraph 6.04);

2. Contractor's disregard of Laws or Regulations of any public body having jurisdiction;

3. Contractor's disregard of the authority of Engineer; or

4. Contractor's violation in any substantial way of any provisions of the Contract Documents.

B. If one or more of the events identified in Paragraph 15.02.A occur, Owner may, after giving Contractor (and surety) seven days written notice of its intent to terminate the services of Contractor:

1. exclude Contractor from the Site, and take possession of the Work and of all Contractor's tools, appliances, construction equipment, and machinery at the Site, and use the same to the full extent they could be used by Contractor (without liability to Contractor for trespass or conversion),

2. incorporate in the Work all materials and equipment stored at the Site or for which Owner has paid Contractor but which are stored elsewhere, and

3. complete the Work as Owner may deem expedient.

C. If Owner proceeds as provided in Paragraph 15.02.B, Contractor shall not be entitled to receive any further payment until the Work is completed. If the unpaid balance of the Contract Price exceeds all claims, costs, losses, and damages (including but not limited to all fees and charges of engineers, architects, attorneys, and other professionals and all court or arbitration or other dispute resolution costs) sustained by Owner arising out of or relating to completing the Work, such excess will be paid to Contractor. If such claims, costs, losses, and damages exceed such unpaid balance, Contractor shall pay the difference to Owner. Such claims, costs, losses, and damages incurred by Owner will be reviewed by Engineer as to their reasonableness and, when so approved by Engineer, incorporated in a Change Order. When exercising any rights or remedies under this Paragraph Owner shall not be required to obtain the lowest price for the Work performed.

D. Notwithstanding Paragraphs 15.02.B and 15.02.C, Contractor's services will not be terminated if Contractor begins within seven days of receipt of notice of intent to terminate to correct its failure to perform and proceeds diligently to cure such failure within no more than 30 days of receipt of said notice.

E. Where Contractor's services have been so terminated by Owner, the termination will not affect any rights or remedies of Owner against Contractor then existing or which may thereafter accrue. Any retention or payment of moneys due Contractor by Owner will not release Contractor from liability.

F. If and to the extent that Contractor has provided a performance bond under the provisions of Paragraph 5.01.A, the termination procedures of that bond shall supersede the provisions of Paragraphs 15.02.B, and 15.02.C.

15.03 *Owner May Terminate For Convenience*

A. Upon seven days written notice to Contractor and Engineer, Owner may, without cause and without prejudice to any other right or remedy of Owner, terminate the Contract. In such case, Contractor shall be paid for (without duplication of any items):

1. completed and acceptable Work executed in accordance with the Contract Documents prior to the effective date of termination, including fair and reasonable sums for overhead and profit on such Work;

2. expenses sustained prior to the effective date of termination in performing services and furnishing labor, materials, or equipment as required by the Contract Documents in connection with uncompleted Work, plus fair and reasonable sums for overhead and profit on such expenses;

3. all claims, costs, losses, and damages (including but not limited to all fees and charges of engineers, architects, attorneys, and other professionals and all court or arbitration or other dispute resolution costs) incurred in settlement of terminated contracts with Subcontractors, Suppliers, and others; and

4. reasonable expenses directly attributable to termination.

B. Contractor shall not be paid on account of loss of anticipated profits or revenue or other economic loss arising out of or resulting from such termination.

15.04 *Contractor May Stop Work or Terminate*

A. If, through no act or fault of Contractor, (i) the Work is suspended for more than 90 consecutive days by Owner or under an order of court or other public authority, or (ii) Engineer fails to act on any Application for Payment within 30 days after it is submitted, or (iii) Owner fails for 30 days to pay Contractor any sum finally determined to be due, then Contractor may, upon seven days written notice to Owner and Engineer, and provided Owner or Engineer do not remedy such suspension or failure within that time, terminate the Contract and recover from Owner payment on the same terms as provided in Paragraph 15.03.

B. In lieu of terminating the Contract and without prejudice to any other right or remedy, if Engineer has failed to act on an Application for Payment within 30 days after it is submitted, or Owner has failed for 30 days to pay Contractor any sum finally determined to be due, Contractor may, seven days after written notice to Owner and Engineer, stop the Work until payment is made of all such amounts due Contractor, including interest thereon. The provisions of this Paragraph 15.04 are not intended to preclude Contractor from making a Claim under Paragraph 10.05 for an adjustment in Contract Price or Contract Times or otherwise for expenses or damage directly attributable to Contractor's stopping the Work as permitted by this Paragraph.

ARTICLE 16 - DISPUTE RESOLUTION

16.01 *Methods and Procedures*

A. Either Owner or Contractor may request mediation of any Claim submitted to Engineer for a decision under Paragraph 10.05 before such decision becomes final and binding. The mediation will be

governed by the Construction Industry Mediation Rules of the American Arbitration Association in effect as of the Effective Date of the Agreement. The request for mediation shall be submitted in writing to the American Arbitration Association and the other party to the Contract. Timely submission of the request shall stay the effect of Paragraph 10.05.E.

B. Owner and Contractor shall participate in the mediation process in good faith. The process shall be concluded within 60 days of filing of the request. The date of termination of the mediation shall be determined by application of the mediation rules referenced above.

C. If the Claim is not resolved by mediation, Engineer's action under Paragraph 10.05.C or a denial pursuant to Paragraphs 10.05.C.3 or 10.05.D shall become final and binding 30 days after termination of the mediation unless, within that time period, Owner or Contractor:

1. elects in writing to invoke any dispute resolution process provided for in the Supplementary Conditions, or

2. agrees with the other party to submit the Claim to another dispute resolution process, or

3. gives written notice to the other party of their intent to submit the Claim to a court of competent jurisdiction.

ARTICLE 17 - MISCELLANEOUS

17.01 *Giving Notice*

A. Whenever any provision of the Contract Documents requires the giving of written notice, it will be deemed to have been validly given if:

1. delivered in person to the individual or to a member of the firm or to an officer of the corporation for whom it is intended, or

2. delivered at or sent by registered or certified mail, postage prepaid, to the last business address known to the giver of the notice.

17.02 *Computation of Times*

A. When any period of time is referred to in the Contract Documents by days, it will be computed to exclude the first and include the last day of such period. If the last day of any such period falls on a Saturday or Sunday or on a day made a legal holiday by the law of the applicable jurisdiction, such day will be omitted from the computation.

17.03 *Cumulative Remedies*

A. The duties and obligations imposed by these General Conditions and the rights and remedies available hereunder to the parties hereto are in addition to, and are not to be construed in any way as a limitation of, any rights and remedies available to any or all of them which are otherwise imposed or available by Laws or Regulations, by special warranty or guarantee, or by other provisions of the Contract Documents. The provisions of this Paragraph will be as effective as if repeated specifically in the Contract Documents in connection with each particular duty, obligation, right, and remedy to which they apply.

17.04 *Survival of Obligations*

A. All representations, indemnifications, warranties, and guarantees made in, required by, or given in accordance with the Contract Documents, as well as all continuing obligations indicated in the Contract Documents, will survive final payment, completion, and acceptance of the Work or termination or completion of the Contract or termination of the services of Contractor.

17.05 *Controlling Law*

A. This Contract is to be governed by the law of the state in which the Project is located.

17.06 *Headings*

A. Article and paragraph headings are inserted for convenience only and do not constitute parts of these General Conditions.

This page was intentionally left blank.

NOTE: The required limits of liabilities may be obtained with primary liability policies or in combination with an umbrella excess third party liability policy.

SC 5.6 This section is deleted.

SC 5.7 This section is deleted.

SC 20.1 FAILURE TO COMPLETE WORK ON TIME.

Should the CONTRACTOR or the Surety fail to complete the WORK within the time agreed upon, or within such extra time as may be allowed by extensions, there shall be deducted from any monies due or that may become due the CONTRACTOR or Surety the sum of **\$500.00** for each and every calendar day, including Sundays and holidays, that the WORK shall remain uncompleted. This sum shall be considered and treated not as a penalty but as fixed, agreed and liquidated damages due the OWNER from the CONTRACTOR or Surety by reason of inconvenience to the public, added cost of engineering and other costs incurred resulting from his failure to complete the WORK within the time specified.

SC 20.2 Permitting the CONTRACTOR or Surety to continue and finish the WORK or any part of it after the time fixed for its completion, or after the date to which the time for completion may have been extended, shall in no way operate as a waiver on the part of the OWNER of any of its rights under the CONTRACT.

SC 22.0 Notice to Fire, Police and Sheriff's Departments: The CONTRACTOR shall give written notice to the Fire and Police Departments of the municipality in which the WORK is being performed and/or to the Sheriff's Department at least twenty-four (24) hours before closing off or in any manner affecting through vehicular traffic on any street.

SC 23.0 In any case where the GENERAL CONDITIONS - PART 5 and the GENERAL SPECIFICATIONS - PART 7 of these CONTRACT DOCUMENTS overlap or conflict, the more restrictive section shall apply.

GENERAL SPECIFICATIONS - PART 7

1. MATERIALS AND WORKMANSHIP

- 1.1. Unless otherwise stipulated in the SPECIFICATIONS, all workmanship, equipment, materials and articles incorporated in the WORK covered by the CONTRACT DOCUMENTS are to be new and of the best grade of their respective kinds for the purpose. The CONTRACTOR shall, if required, furnish such evidence as to kind and quality of materials. The CONTRACTOR shall furnish to the OWNER for his approval, the name of the manufacturer of machinery, mechanical and other equipment, which he contemplates installing, together with their performance capacities and other pertinent information.
- 1.2. If not otherwise provided, material or WORK called for in the CONTRACT DOCUMENTS shall be furnished and performed in accordance with well-known established practice and standards recognized by architects, engineers and the trades.
- 1.3. When required by the SPECIFICATIONS, or when called for by the OWNER, the CONTRACTOR shall furnish the OWNER for review full information concerning the materials which he contemplates incorporating in the WORK. Samples of materials shall be submitted for approval when so directed. Machinery, equipment, materials and articles installed or used without such approval shall be at the risk of subsequent rejection.

2. DRAWINGS AND SPECIFICATIONS

- 2.1. The WORK shall be executed in strict conformity with the DRAWINGS and SPECIFICATIONS and the CONTRACTOR shall do no WORK without proper DRAWINGS and SPECIFICATIONS.
- 2.2. Unless otherwise provided in the CONTRACT DOCUMENTS the OWNER will furnish the CONTRACTOR free of charge, all copies of DRAWINGS and SPECIFICATIONS reasonably necessary to carry out the WORK.
- 2.3. The CONTRACTOR shall keep at the site of the WORK an approved or confirmed copy of the CONTRACT DOCUMENTS and shall at all times give the OWNER access thereto. In case of differences between the DRAWINGS and SPECIFICATIONS, the SPECIFICATIONS will govern.

3. SHOP DRAWINGS

- 3.1. The CONTRACTOR shall submit to the OWNER or OWNER'S representative, all shop or setting DRAWINGS and schedules required for the WORK. The CONTRACTOR shall make any corrections in the SHOP DRAWINGS required by the CONTRACT DOCUMENTS and resubmit same without delay.

4. SPECIAL SPECIFICATIONS

- 4.1. SPECIAL SPECIFICATIONS shall take precedence over all other DRAWINGS and SPECIFICATIONS.

5. LINE AND GRADE

- 5.1. All lines and grades required shall be laid out by the ENGINEER. The CONTRACTOR shall notify the ENGINEER 48 hours in advance of his intention to start any portion of the WORK.
- 5.2. The CONTRACTOR shall carefully preserve all stakes, reference points, etc. against destruction and shall promptly notify the ENGINEER of any stakes which have been disturbed. In case of willful or careless destruction, the CONTRACTOR will be charged with the expense and damage from such destruction.

6. INFORMATION ON DRAWINGS

- 6.1. The existence and location of underground utilities indicated on the DRAWINGS are not guaranteed and shall be investigated and verified in the field by the CONTRACTOR before starting the WORK. Excavation in the vicinity of existing structures and utilities shall be carefully done by hand.
- 6.2. The CONTRACTOR shall be held responsible for any damage to, and for maintenance and protection of existing utilities and structures whether shown on DRAWINGS or not.

7. WORK ON RAILROAD RIGHT-OF-WAY

- 7.1. All the WORK done within the right-of-way of a railroad shall have prior approval of, and be subject to the inspection of the railroad concerned. The OWNER shall secure prior approval and fit the construction DRAWINGS to the railroad's requirements. The CONTRACTOR shall so conduct his operations as to meet these requirements. Certified copy of written approval of the railroad as to construction methods and materials shall be furnished to the OWNER.

8. WORK ON STATE RIGHT-OF-WAY

- 8.1. All WORK done within the right-of-way of the State shall have the prior approval of, and be subject to the inspection of, the particular State agency involved. The OWNER shall secure permits for the construction in, along or across State or U.S. Highways, but complete control of the construction will be by the State agency officials.

9. OR EQUIVALENT CLAUSE

- 9.1. Whenever in any section of the CONTRACT DOCUMENTS any article, material, or equipment, is defined by describing a proprietary product, or by using the name of the manufacturer or vendor, the term "or equivalent", if not inserted, shall be implied. The specific article, material, or equipment mentioned shall be understood as indicating the type, function, minimum standard of design, efficiency and quality desired and, shall not be construed in such a manner as to exclude manufacturers products of comparable quality, design, or efficiency.

10. PUBLIC CONVENIENCE AND SAFETY

- 10.1. Where roads affected by this construction WORK are required to be kept open to travel, the same shall be maintained in a safe condition. The CONTRACTOR shall be responsible under his BID for all accidents that may occur due to an unsafe condition of the road, which condition may have been caused by the CONTRACTOR'S operations. The CONTRACTOR shall post signs warning the public of the probably increased danger due to construction. Until the WORK is accepted, the CONTRACTOR shall take all necessary precautions and place proper guards and barriers around the WORK and shall, between sundown and sunrise, maintain suitable red lights as warning signals. When a public road is kept closed to travel, the CONTRACTOR shall erect and maintain suitable barriers at each end of the WORK and shall post such detour signs to direct the traveling public around the WORK constructed.

11. SANITARY REQUIREMENTS

- 11.1. The CONTRACTOR shall provide and maintain on the construction site at all times, suitable sanitary facilities for use of those employed on this PROJECT without committing any public nuisance. All sanitary facilities shall be maintained in a sanitary condition and their use strictly enforced.

12. TEMPORARY LIGHT AND POWER

- 12.1. Should temporary electric light be necessary for the execution of this WORK at any time, the CONTRACTOR shall provide and pay for all such light and power. This will include all necessary wiring, fixtures, electric bulbs. Torches or other sources of light which

cause damage by fire or by smoke shall not be used. The CONTRACTOR shall arrange and pay for all electric power required for construction purposes.

13. CONSTRUCTION SAFETY AND HEALTH

13.1. Precaution shall be exercised at all times for the protection of persons (including employees) and property. The safety provisions of all applicable laws, building, and construction codes shall be observed. All construction procedures, machinery, and equipment shall meet the requirements of the Occupational Safety and Health Act of 1970, Part 1926 (Safety and Health Regulations for Construction) of Title 29 of the Code of Federal Regulations, and Chapter IND 1000 (Safety and Health) of the Wisconsin Administrative Code.

13.2. The CONTRACTOR shall put and maintain such barriers and supply such watchmen as will effectively prevent accidents and in addition, during night hours shall put up and maintain sufficient lights and flares to warn and safeguard the public against accidents.

14. WORK IN BAD WEATHER

14.1. No construction WORK shall be done during stormy, freezing or inclement weather, except such as can be done • satisfactorily, and in such a manner to secure first class construction throughout, and then only subject to permission of the OWNER.

15. PROTECTION OF WORK

15.1. The CONTRACTOR shall continuously maintain adequate protection of all WORK from damage and shall protect the OWNERS and adjacent property from injury arising in connection with the PROJECT.

16. USE OF JOB SITE

16.1. The CONTRACTOR shall confine his equipment, apparatus, the storage of materials and operations of his workmen to limits indicated by law, ordinances, permits or directions of the OWNER and shall not encumber the premises with his materials.

16.2. The CONTRACTOR shall not load or permit any part of any structure to be loaded with a weight that will endanger its safety. The CONTRACTOR shall enforce the OWNERS authorized representative instructions regarding signs, advertisements, fires and smoke.

17. CUTTING AND PATCHING

17.1. The CONTRACTOR shall do all necessary cutting and patching of the WORK that may be required to properly receive the WORK of the various trades or as required by the DRAWINGS and SPECIFICATIONS to complete the structure. He shall restore all such cut or patched work as recommended by the OWNER. Cutting of existing structure that may endanger the work, adjacent property, workmen or the public shall not be done.

17.2. All existing pavement or base course removed or damaged must be replaced with the same type of material.

17.3. Blacktop and concrete surfaces shall be saw cut before excavation.

17.4. Any cost caused by defective or ill-timed WORK shall be borne by the party responsible. The CONTRACTOR shall not endanger any work by cutting, digging or other method and shall not cut or alter the WORK of any other CONTRACTOR without the consent of the OWNER or the OWNER'S authorized representative.

18. CLEANING UP

18.1. The CONTRACTOR shall at all times keep the premises free from accumulations of waste material or rubbish caused by his employees or WORK and at the completion of the WORK he shall remove all his rubbish from and about the PROJECT including all his tools, equipment, scaffolding and surplus materials and shall leave his WORK clean and ready for

use. In case of dispute, the OWNER may remove the rubbish and surplus materials and charge the cost to the several CONTRACTORS in proportion to the amounts as shall be determined to be just.

19. PROPERTY MARKERS

19.1. The CONTRACTOR shall be responsible for the damage or destruction of any property markers. No such markers shall be removed without first having been witnessed or referenced by a Registered Land Surveyor or his agent.

20. RECORD DRAWINGS

20.1. CONTRACTOR shall be required to take and record as-constructed measurements on a set of DRAWINGS. Such measurements shall include sufficient information so that record DRAWINGS of the PROJECT can be prepared.

SPECIAL SPECIFICATIONS - PART 8

**MARY HILL PARK
SANITARY SEWER RELOCATION
CITY OF FOND DU LAC, FOND DU LAC COUNTY, WISCONSIN**

Project No. 828.002

SPECIAL SPECIFICATIONS TAKE PRECEDENCE OVER ALL OTHER DRAWINGS AND SPECIFICATIONS.

These Special Provisions shall govern over any differences of any other specifications of this contract. Other specifications included in this contract are: Detailed Specifications for Sewer Construction, Bidders should note that in cases not defined in the above specifications, that the Standard Specifications for Highway and Structure Construction, of the State of Wisconsin - Department of Transportation (latest edition), hereinafter abbreviated as WDOT, and the Standard Specifications for Sewer and Water Construction in Wisconsin (6th Edition), hereinafter abbreviated as WS&W, shall govern. Any reference to the "State" or "Department" in said Standard Specifications shall mean the "City of Fond du Lac" for the purposes of this contract.

GENERAL

1. Referenced Specifications:

ASTM	American Society for Testing and Materials
WisDOT Std. Spec.	State of Wisconsin Department of Transportation Standard Specifications for Highway and Structure Construction, current Edition and all supplemental provisions
Standard Specifications	Standard Specifications for Sewer and Water Construction In Wisconsin, current Edition and all addendums

Whenever in the specifications, or in any documents or plans related to the construction operations, the reference is made to the specifications or designation of ASTM, AASHTO, ANSI or AWWA the intent and meaning shall be interpreted to be the use of the latest revision.

2. Construction and materials, in addition to following the City of Fond du Lac's Standard Special Provisions, shall also meet the requirements of the WisDOT Standard Specifications for Highway and Structure Construction, and Standard Specifications for Sewer and Water Construction in Wisconsin.
3. The CONTRACTOR shall procure and pay for all permits, licenses and bonds necessary for the prosecution of the WORK, and/or required by the Municipal, State and Federal regulations and laws, unless specifically provided otherwise in the Special Conditions of the CONTRACT and/or in the CONTRACT SPECIFICATIONS.
4. The locations of existing underground utilities are shown in an approximate way only and have not been independently verified by the Owner or its representative. The CONTRACTOR shall determine the exact location of all existing utilities before

commencing Work and agrees to be fully responsible for any and all damages that might be occasioned by the CONTRACTOR's failure to exactly locate and preserve any and all underground utilities.

5. The CONTRACTOR shall notify the proper utility company prior to excavating in the vicinity of underground conduits or cables. If such conduits or cables are in the way of proposed structures, the CONTRACTOR shall make arrangements with the utility companies to have the locations of such conduits or cables adjusted.
6. The CONTRACTOR shall abide by the regulations set forth by the Federal Department of Labor Manual, "Safety and Health Regulations for Construction."
7. The Owner will schedule a preconstruction meeting prior to the start of construction.
8. The CONTRACTOR shall insure that no construction activity occurs on privately owned property without the permission of the property Owner.
9. The CONTRACTOR shall comply with all State, County and Local ordinances and permits during the course of this construction.
10. The CONTRACTOR shall submit to the Engineer two copies of current manufacture's specifications, mix designs, sieve and fracture analyses and construction details for review prior to installation or fabrication. All submittals shall be provided a minimum of one week before a proposed material will be used or a structure will be constructed or installed. Each submittal shall indicate the proposed material or structure, compliance with specified standard(s), supplier and manufacturer's name, address and phone number. The Contractor may consider a submittal reviewed upon receiving one copy bearing the stamp of review and signature of the Engineer. Any submittal rejected by the Engineer shall be resubmitted for approval prior to installation or fabrication. No materials subject to construction detail review shall be ordered prior to receipt of an approved submittal. Materials installed shall match approved submittals. The City reserves the right to randomly sample and test at any time during the project.

ACCURACY AND COMPLETENESS OF PLANS

11. The plans for the project represent what is thought to be an accurately designed construction project. However, errors and oversights may occur on these documents. The CONTRACTOR and the engineer shall work to resolve any discrepancy and neither party shall use such an error or oversight to gain an advantage.

SUBCONTRACTORS

12. Pursuant to Section 66.29 (7), Wisconsin Statutes, each bidder is required to submit a full and complete list of all subCONTRACTORS and the class of work to be performed by each subCONTRACTOR on this project. A "List of SubCONTRACTORS" form is included in these contract documents, which shall be completed by each bidder of this project. If there are to be no subCONTRACTORS on this work, the bidder shall so indicate on said form. Failure to provide this information may result in rejection of bid.

EXTRA WORK

13. The Engineer reserves and shall have the right to make such changes, from time to time, in the plans, the character, or quantity of the work as may be considered necessary or desirable to complete fully and acceptably the proposed construction in

a satisfactory manner, provided such alterations do not change the total cost of the project, based on the originally estimated quantities and the unit prices bid, by more than twenty-five percent (25%), and provided further that such alterations do not change the total cost of any major item, based on the originally estimated quantities and the unit prices bid, by more than twenty-five percent (25%). (A major item shall be construed to be any item, the total cost of which is equal to or greater than ten percent (10%) of the total contract price, computed on the basis of the proposal quantity and the contract unit price). Should it become necessary, for the best interest of the Owner, to make changes in excess of that herein specified, the same shall be covered by supplemental agreement.

14. The CONTRACTOR shall not start work on any alterations requiring a supplemental agreement until the agreement setting forth the adjusted prices shall be executed by the Owner and the CONTRACTOR.
15. Should any of the changes not requiring supplemental agreements be made as provided herein, the CONTRACTOR shall perform the work as altered, increased or decreased at the contract unit price or prices.
16. In case a satisfactory adjustment in price cannot be reached for any item requiring a supplemental agreement, the Owner reserves the right to terminate the contract as it applies to the items in question and make such arrangements as may be deemed necessary to complete the work.
17. When work is necessary to the proper completion of the project for which no quantities or prices were given in the proposal or contract, the same shall be called extra work and shall be performed by the CONTRACTOR when so directed by the Engineer. Extra work shall be performed by the CONTRACTOR in accordance with these specifications in a proper and workmanlike manner and as may be directed by the Engineer.
18. Prices for extra work shall be itemized and covered by a supplemental agreement submitted by the CONTRACTOR and approved by the Owner prior to the actual starting of such work. Should the parties be unable to agree on unit prices for the extra work or if the method is impractical, the engineer may instruct the CONTRACTOR to proceed with the work by day, labor or force account as provided for in the payment for force account work in the General Specifications. Claims for extra work not authorized in writing by the engineer prior to the work being done will be rejected.

MAINTENANCE OF TRAFFIC & ACCESS TO PROPERTIES

19. The CONTRACTOR shall provide a local person responsible for providing and maintaining warning lights and barricades on the project whenever the CONTRACTOR shuts down his operations for a period of time, including nights and weekends. His name, address, and telephone number shall be given to the Engineer, the Public Works Director, and the Police Department.
20. The CONTRACTOR shall provide all barricades, warning signs, and flagmen in accordance with the Federal Highway Administration Manual on Uniform Traffic Control Devices.
21. The CONTRACTOR shall maintain a minimum of one lane of traffic through the project limits for residents, access to businesses, and emergency vehicles at all times. Where utility crossings or tie-in connections are required through an

intersection or into a through street the CONTRACTOR shall make provisions to maintain a minimum one lane of traffic at all times. Traffic control shall be by designated "flagging operations" and/or proper signage according to the plan details, General Specifications, the Federal Highway Administration Manual on Uniform Traffic Control Devices and WDOT Work Zone Safety Guide (latest edition). A traffic control plan shall be submitted and approved by the Engineer prior to work being performed of which would restrict the normal traffic patterns on and adjacent to the project limits.

22. All-weather access to properties via driveways shall be maintained at all times with the exception of concrete cure time. Provision shall be made by the CONTRACTOR for gapping, partial pours, or alternate temporary access points to provide access at all times to businesses or special needs/handicap needs residents. Access provisions shall be subject to approval by the Engineer.
23. The CONTRACTOR is required to use drums, cones, flaggers, or temporary fencing, in addition to the traffic control for the motorists, to delineate and protect the public from temporary hazards, equipment operations, and any other hazardous conditions that are a result of the construction activity.
24. The supply and maintenance of all traffic control devices and access costs shall be incidental to the Contract.

HAUL ROUTES

25. During the construction of this contract, the Contractor and all of his representatives will be restricted as to the streets which may be used for the transport of materials and equipment. The City will require the Contractor and subcontractors use main arterials and non-residential streets. Designated heavy traffic routes may be found at <https://ecode360.com/15560916#15560916>. The contractor shall supply the proposed haul routes to the Engineer prior to commencing hauling. The Contractor and the Engineer will mutually cooperate to establish haul routes that are satisfactory to both parties while protecting other streets from damage. The Contractor shall monitor and remove tracked soils from haul routes.

GRADE AND ALIGNMENT STAKING

26. The Owner will provide line and grade stakes for construction. Staking requests shall be made a minimum of **three (3) working days** prior to the time the stakes are needed. The CONTRACTOR shall take adequate measures to protect said stakes, and if such stakes are knocked or disturbed by carelessness of the CONTRACTOR or his forces, the cost of resetting such stakes will be directly billed to the CONTRACTOR.
27. Construction line and grade stakes will be set by the Engineer **one time only**. It shall be the CONTRACTOR's responsibility to protect and preserve the stakes. Additional staking will be charged to the CONTRACTOR.

DUST CONTROL

28. If in the Engineer's opinion, it becomes necessary to apply a dust palliative along the construction project to relieve abutting property owners from unreasonable dirt and dust conditions, the CONTRACTOR shall furnish and apply such dust preventives at his own expense. The CONTRACTOR shall take all reasonable measures to protect the Owner from extensive complaints regarding dust, as well as complaints

pertaining to dirt or debris dropped on streets leading to the waste disposal areas during old pavement removal and excavating operations.

PROTECTION OF PROPERTY AND OTHER UTILITIES

29. In excavating, the CONTRACTOR must take precautions to protect all private and public property, which might be affected. Damaged property shall be repaired or replaced as directed by the Engineer at the expense of the CONTRACTOR.

SITE RESTORATION AND FINAL CLEAN UP

30. Upon completion of the work and before acceptance and final payment will be made, the Contractor shall remove from the site all machinery, equipment, surplus and discarded materials, rubbish, temporary structures, and stumps or portions of trees. The Contractor shall leave the work site in a condition free from all waste or surplus materials or excavations. All such items shall be removed and disposed in some other acceptable disposal site.

COORDINATION WITH OTHER UTILITIES

31. The CONTRACTOR shall be responsible for notifying the local utilities as to the areas of work and the time that such work is to be completed. The following is a list of local utilities and the local telephone numbers.

Alliant Energy-----	1-800-255-4268
AT&T -----	920-929-1013
AT&T Transmission-----	608-628-0575
Charter-Spectrum Communications -----	920-263-0428
Digger’s Hotline-----	800-242-8511
City of Fond du Lac, Engineering Division -----	920-322-3470
City of Fond du Lac, Department of Public Works-----	920-322-3540

32. The CONTRACTOR shall familiarize themselves with each utility’s regulations as to length of time and method of notification required so that such utility may properly mark their locations in the field.

SANITARY SEWER

33. Sanitary Sewer installation shall be in accordance with the City of Fond du Lac and the Standard Specifications for Sewer and Water Construction in Wisconsin, Sixth Edition. The city’s specifications shall take precedence over the state’s specifications.

34. The work required under this contract was initiated due to the bridge replacement project that Fond du Lac County is undertaking. The successful bidder for this contract must coordinate with Fond du Lac County’s successful bridge contractor, Pheifer Brothers, for access to the sites. Work on the bridge contract is anticipated to start June 16, 2025 and take 70 days to complete.

Sanitary Sewer Material

A. Sanitary sewer shall be Polyvinyl Chloride (PVC) sewer pipe and shall conform to the requirements of ASTM D3034, SDR 35, with integral bell type flexible elastomeric joints meeting the requirements of ASTM D-3212.

- B. Sanitary manholes shall be pre-cast concrete with a 4-foot inside diameter. Manhole frames and covers shall be Neenah R-1550-A, Type B self-sealing lid with concealed pick holes. The frame shall be sealed to the precast manhole with an interior chimney seal, Cretex Specialty products or equal. All joints in the precast manhole shall be sealed using MacWrap external joint seals as well as butyl rubber sealant.
- C. Bedding material from a point 4" below the barrel of the pipe to 12" above the pipe shall be 3/8" crushed stone.
- D. The trenches for the sanitary sewer main and all laterals and appurtenances located in street or driveway crossings, proposed or existing, or within 3' of the edge of pavement shall be backfilled to existing grade with pit-run sand/gravel with no material larger than 2 inches. The trenches not located in street or driveway crossings may be backfilled with excavated material. All excess spoil material shall be removed from the site by the Contractor.
- E. Any bypass pumping required shall be incidental to the contract.
- F. Adjusting Rings shall be precast concrete.
- G. For the manholes that require the elevations to be adjusted, the precast cone may be reused if it matches the new base section with a "tongue and groove" type fit. Butyl rubber sealant and MacWrap external joint seals are required on all exposed or new joints.

TESTING

- 35. Deflection Tests – these tests shall be performed on all PVC main line pipe installed using an approved go-no-go device. The test shall be conducted after all backfill has been placed and consolidated. If testing occurs within 30 days of placement of final backfill, deflection shall not exceed 5%. When testing occurs after 30 days of placement of final backfill, the deflection shall not exceed 7.5%. All testing shall be done under the observation of the Engineer. For acceptance, the device must pass through the entire section between manholes in one pass when pulled by hand without the use of excessive force. Any section not meeting the requirements shall be repaired and retested.
- 36. All sanitary sewers are required to pass a low pressure air test or water infiltration test in accordance with Chapter 3.7.0 of the WS&W.
- 37. All testing shall be done under the observation of the Engineer. Any section not meeting the requirements shall be repaired and retested.
- 38. The expense for testing and repairing, if necessary, shall be included in the price bid for 8" PVC Sanitary Sewer.

SANITARY MANHOLE FRAMES AND COVERS

- 39. Payment for the frame and cover shall be incidental to the price bid for manhole.

ADJUSTING MANHOLE CASTINGS

- 40. Payment for new manholes to be built on this project includes the furnishing and setting of the manhole frames and covers to finished grade including all necessary adjustment.

41. Adjustment of existing sanitary sewer or storm sewer manhole castings shall be included in 4' Diameter Sanitary Manhole. All the adjusting rings shall be removed to the manhole cone or flat top unless directed otherwise. Adjustment shall include replacement of up to 12 inches of concrete rings and mortar with precast concrete rings. One concrete ring may be used if the required adjustment exceeds 12 inches.
42. Abandon Sanitary Manhole shall include removing the casting, rings, and eccentric cone to a point at least 2 feet below existing grade. Influent and Effluent pipes shall be sealed with non-shrink grout. The manhole base shall be filled with granular material, then the excavation shall be brought up to grade with spoil material, or as the engineer directs.

EROSION CONTROL MEASURES

43. CONTRACTOR shall install and maintain erosion control measures as shown on the plans and in compliance with the City's Erosion and Sediment Control Specifications. The erosion control measures shall be properly maintained by the CONTRACTOR until final acceptance by the Owner. Construction operations shall be conducted in a manner to minimize soil erosion. Silt fences, seeding, erosion bales, erosion mat, tracking pads, and other measures shall be used to insure that soil from the site does not enter adjoining property.
44. During construction off site areas shall be inspected daily for tracked material and shall be cleaned daily as necessary. Any and all excess material left after construction shall be disposed of on site.
45. The cost of erosion control measures, excepting those explicitly listed within the Bid Form, shall be incidental to the Contract.
46. All CONTRACTORS and Sub-CONTRACTORS shall be responsible for preserving the integrity of said Erosion Control Measures.

SILT FENCE

47. Silt Fence shall be installed in accordance with Section 628 of the WisDOT Std. Spec. and D.O.T. Standard Detail Drawing 8 E 9-6, except the basis of payment shall be as indicated in the Schedule of Prices for Silt Fence and shall include delivery, installation, and maintenance of the respective item.

RESTORATION

48. All disturbed areas outside of pavement on this project shall be topsoiled, fertilized, seeded and mulched. Fertilizing, seeding, and mulching of the topsoiled areas shall be in accordance with Sections 629, 630, and 627 respectively, of the WisDOT Standard Specifications
49. Topsoil shall be placed to a minimum depth of 4 inches deep. The CONTRACTOR shall do sufficient raking to provide a well-graded appearance.
50. The CONTRACTOR shall apply fertilizer at a rate of 10 pounds per 1000 square feet. Fertilizer shall be evenly mixed into the top two inches of topsoil.
51. Topsoil, seed, fertilizer, and mulch shall bid as a lump sum. The cost of any restoration needed outside limits of construction as shown on the plan due to CONTRACTOR negligence shall be borne by the CONTRACTOR.

52. Seeding performed after September 15 shall use either a bonded fiber matrix or an erosion mat. Bonded fiber matrix shall be ProMatrix Engineered Fiber Matrix, as manufactured by Profile Products or approved equal and shall be applied as specified above. Erosion mats installed for late season restoration shall be a Class I, Urban, Type A product on the PAL.
53. Temporary seeding shall be applied to disturbed areas as shown on the plans or as directed by the Engineer. Temporary seeding shall be applied to disturbed areas at a minimum weekly or more frequently as directed by the Engineer. The Contractor shall apply a total amount of 3 pounds per 1,000 square feet on all restoration areas. Temporary seeding shall consist of annual oats for spring and summer plantings and winter wheat or agricultural rye for fall plantings after September 1st. Temporary seeding areas shall be fertilized, mulched and watered as necessary to establish adequate vegetation.

ROCK EXCAVATION

54. Rock Excavation shall be measured from the top of rock to the bottom of trench at a width of 3 feet. The CONTRACTOR shall not be paid for excess rock excavation.
55. Any rock excavation shall be approved by the engineer prior to construction and measured by the engineer after construction. If this procedure is not followed, the CONTRACTOR will not be paid for any work that may be classified as rock excavation.

GUARANTEE

56. The CONTRACTOR shall agree and guarantee that the materials and workmanship supplied by him shall be free from all defects and strictly in accordance with the plans and specifications at the time of its completion and acceptance by the City and for a period of one (1) year thereafter; should defects in said materials or workmanship appear within the time just specified, the CONTRACTOR agrees to forthwith repair the same upon notification by the City, using the same material required by these specifications and in case said defects must be repaired by the City, the CONTRACTOR shall agree to pay on demand the cost thereof to said City upon completion of such repairs.
57. The Contractor further agrees and guarantees to pay for all labor and material used in or about the construction of said work in his contract, which may become a lien or claim against the City. Such agreement and guarantee shall be made a part of the contract and the fulfillment thereof shall be secured by the bond of the Contractor.

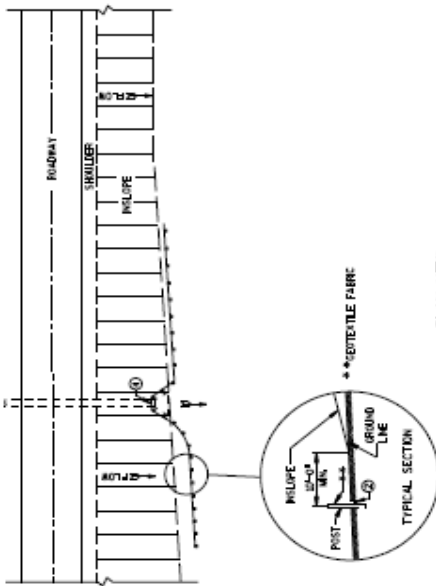

TYPICAL APPLICATION OF SILT FENCE

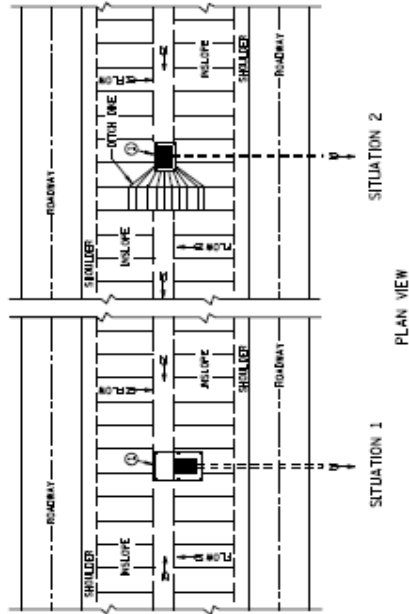

SILT FENCE AT MEDIAN SURFACE DRAINS

- GENERAL NOTES**
- DETAILS OF CONSTRUCTION NOT SHOWN ON THIS DRAWING SHALL CONFORM TO THE REQUIREMENTS OF THE STANDARD SPECIFICATIONS AND APPLICABLE SPECIAL PROVISIONS.
 - HORIZONTAL BRACE REQUIRED WITH 2" x 4" WOODEN FRAME OR EQUIVALENT AT TOP OF POSTS.
 - FOR MANUAL INSTALLATIONS THE TRENCH SHALL BE A MINIMUM OF 4" DEEP & 6" WIDE TO BURY AND ANCHOR THE GEOTEXTILE FABRIC. FOLD MATERIAL TO FIT TRENCH AND BACKFILL & COMPACT TRENCH WITH EXCAVATED SOIL.
 - WOOD POSTS SHALL BE A MINIMUM SIZE OF 6" x 6" IF ONE OF HEIGHT.
 - SILT FENCE TO EXTEND ACROSS THE TOP OF THE PIPE.
 - CONSTRUCT SILT FENCE FROM A CONTINUOUS ROLL IF POSSIBLE BY CUTTING LENGTHS TO AVOID JOINTS. IF A JOINT IS NECESSARY USE ONE OF THE FOLLOWING TWO METHODS TO OVERLAP THE END POSTS AND TRENCH OR ROTATE, AT LEAST 90 DEGREES, BEHIND THE END OF EACH SILT FENCE LENGTH.

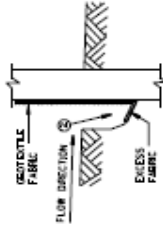

TRENCH DETAIL

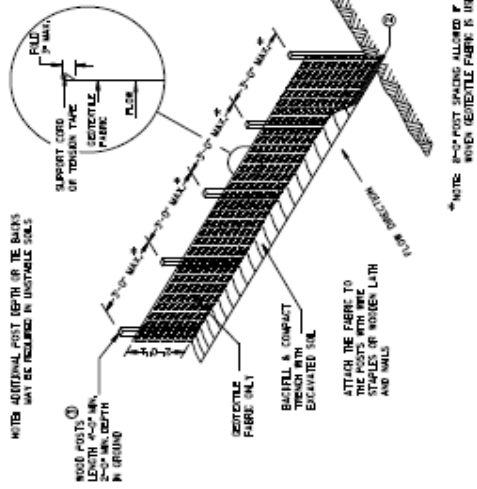

SILT FENCE

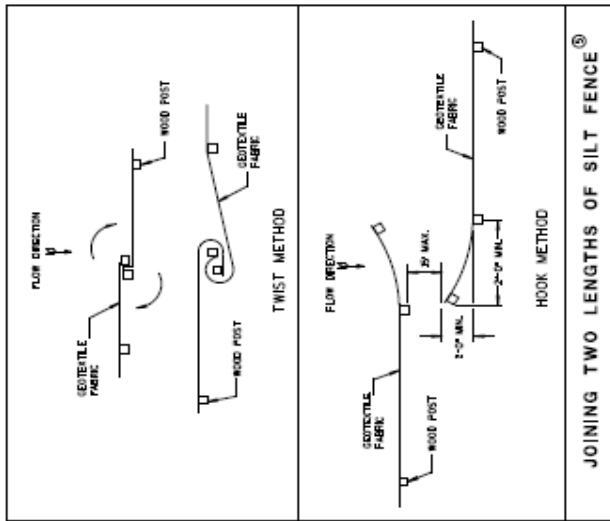

JOINING TWO LENGTHS OF SILT FENCE

SILT FENCE	
STATE OF WISCONSIN	
DEPARTMENT OF TRANSPORTATION	
APPROVED:	DESIGNED/DATE:
4-28-83	1987 ROADWAY DEVELOPMENT DIVISION
PWA	

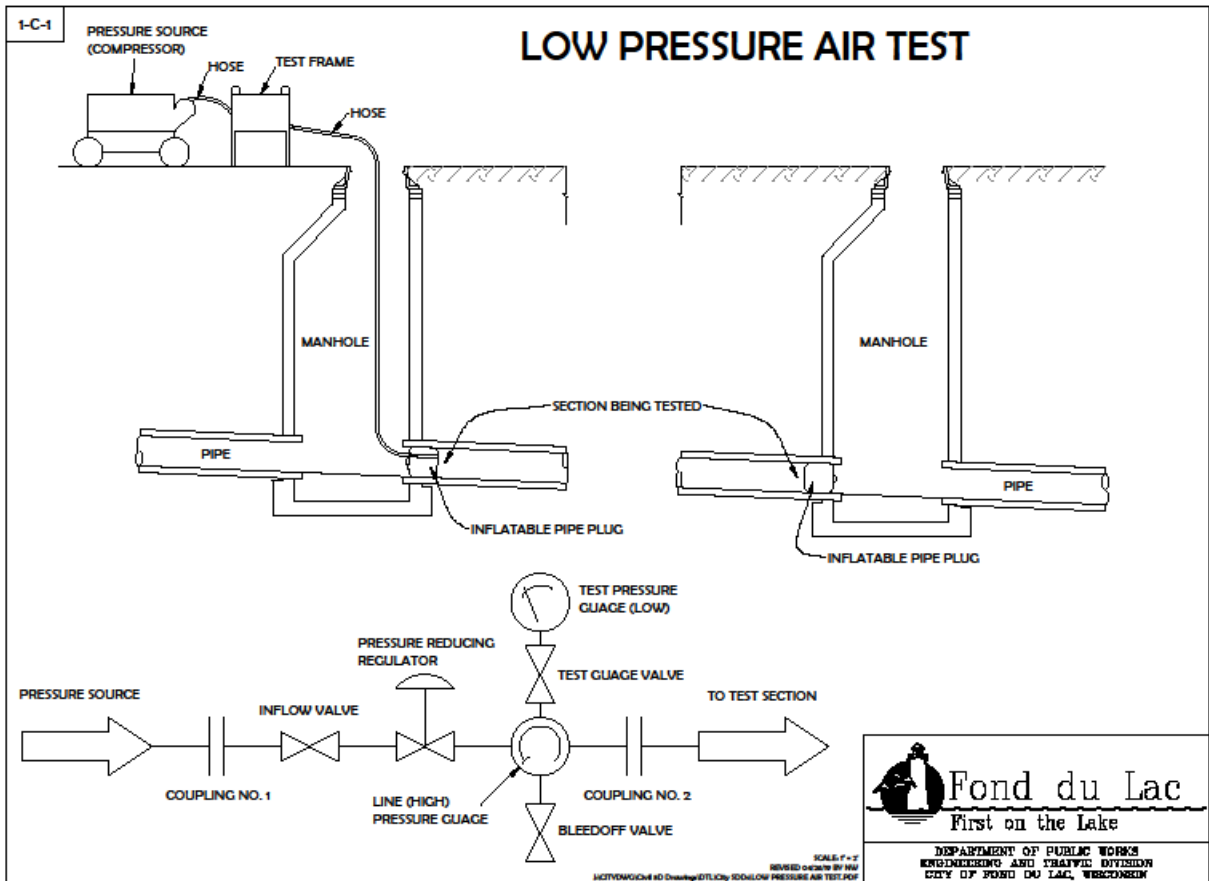

1-B-2

STANDARD MANHOLE INVERTS

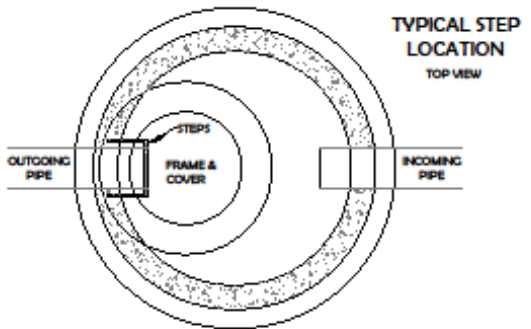
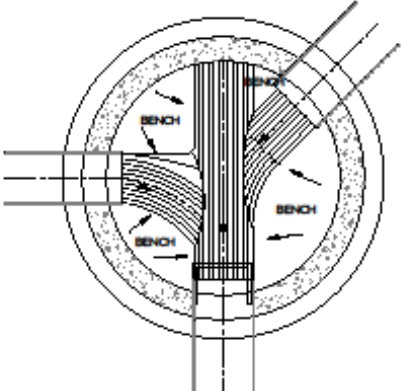
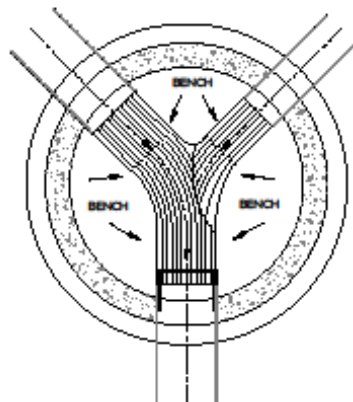
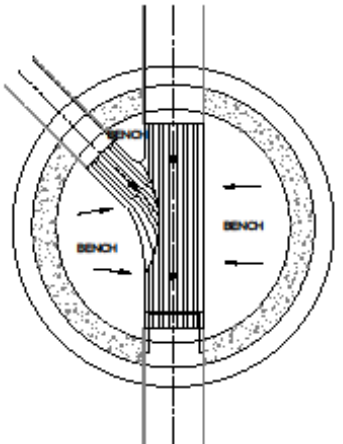
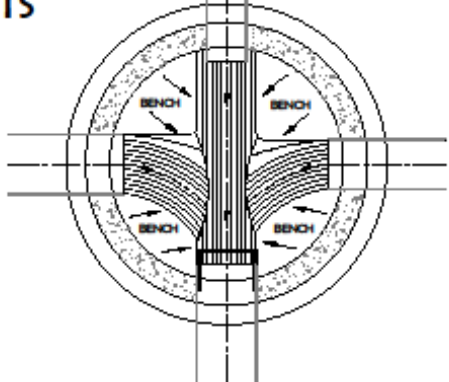
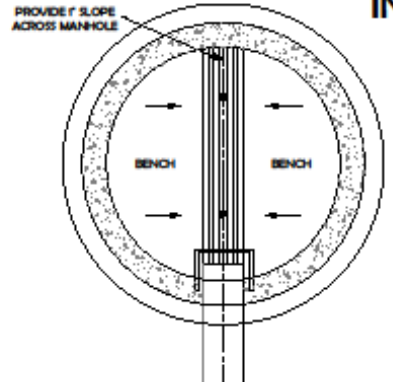

HEIGHT OF BENCH TO BE 0.8 X DIA. OF SEWER
 STORM SEWER BENCH SLOPE - 1 INCH PER FT
 SANITARY SEWER BENCH SLOPE - 3 INCHES PER FT

SIDE CONNECTING MAINS SHALL HAVE FULL SWEEP CURVATURE INTO MAIN FLOW LINE

MANHOLE STEPS SHALL BE ALIGNED OVER THE OUTGOING PIPE

REVISED 1/2008 BY MW
 MCFY5W60244 40 Drawing (D) City 100 STANDARD MANHOLE INVERT/PLP

Fond du Lac
 First on the Lake

DEPARTMENT OF PUBLIC WORKS
 ENGINEERING AND TRAFFIC DIVISION
 CITY OF FOND DU LAC, WISCONSIN

STANDARD PRECAST MANHOLE DETAIL

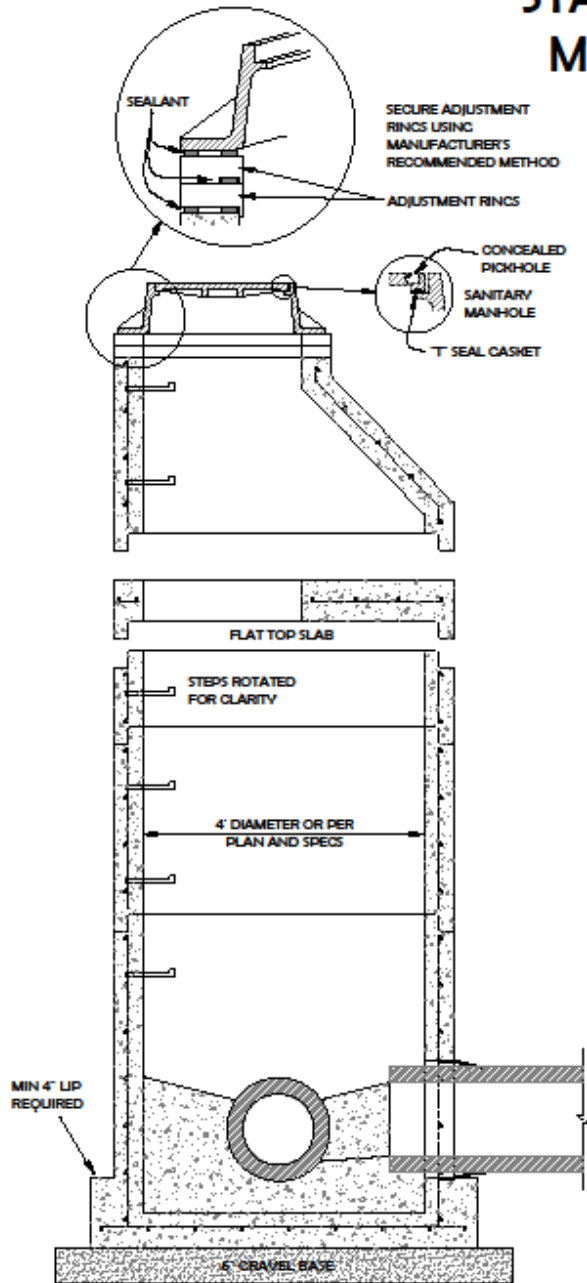

- 6 INCHES OF CRUSHED STONE BASE REQUIRED
- CONCRETE AND STEEL REINFORCEMENT SHALL CONFORM TO ASTM DESIGNATION C478
- MANHOLE CONCRETE STRENGTH TO BE 4,000 PSI OR GREATER
- MIN. MANHOLE WALL, BASE & FLAT TOP SLAB THICKNESSES
 4 FT LD.: 5 INCH WALL, 6 INCH BASE & FLAT TOP SLAB
 5 FT LD.: 6 INCH WALL, 8 INCH BASE & FLAT TOP SLAB
 6 FT LD.: 7 INCH WALL, 8 INCH BASE & FLAT TOP SLAB
 8 FT LD.: 9 INCH WALL, 8 INCH BASE & FLAT TOP SLAB
- MANHOLE BASE TO BE CONSTRUCTED OF CLASS "C" CONCRETE, MINIMUM OF 12 INCHES PLACED UNDER FLOW LINE OF PIPE
- HEIGHT OF BENCH TO BE 0.8 X DIA. OF SEWER
 STORM SEWER BENCH SLOPE - 1 INCH PER FT
 SANITARY SEWER BENCH SLOPE - 3 INCHES PER FT
- PIPE HOLES TO BE MANUFACTURED SO AS TO ALLOW FOR LATERAL AND VERTICAL MOVEMENT, AS WELL AS ANGULAR ADJUSTMENT THROUGH 15°
- PIPE TO MANHOLE CONNECTORS SHALL MEET ASTM C923 (KOR-N-SEAL, QUIK-LOK OR EQUAL)
- JOINTS SHALL BE WATERTIGHT AND SHALL BE MADE USING RUBBER TYPE CASSETS OR PRE-FORMED JOINT MATERIAL
- MANHOLE STEPS TO BE PLACED AT 16 INCH INTERVALS. THE FIRST STEP SHALL BE PLACED 16 INCHES ABOVE THE BENCH. THE TOP STEP MAY VARY FROM 16 INCHES - 24 INCHES FROM THE TOP OF CASTING. STEPS SHALL BE STEEL REINFORCED PLASTIC. MANHOLE STEPS SHALL BE ALIGNED OVER THE OUTGOING PIPE.
- BARREL SECTION - 12 INCH, 16 INCH, 24 INCH, 32 INCH, 48 INCH AND 64 INCH HIGH. AREA OF CIRCUMFERENTIAL STEEL = 0.02 SQ INCH PER LINEAL FOOT
- ECCENTRIC CONE MAY VARY IN HEIGHT FROM 28 INCHES TO 36 INCHES
- INSTALL FLAT TOP WHEN SHOWN ON PLANS, IN SPECIFICATIONS OR APPROVED BY ENGINEER
- ADJUSTMENT RINGS SHALL BE HDPE ADJUSTING RINGS BY LADTECH, INC., CRETEX PRO-RING, OR EJ INFRA-RISER. RINGS SHALL HAVE AN INSIDE DIAMETER OF APPROX. 23-34 INCHES. CONCRETE ADJUSTMENT RINGS SHALL NOT BE ALLOWED.
- FRAME SHALL BE NEEHAH FOUNDRY R-650 OR EQUAL
- SANITARY MANHOLE LID TO HAVE CONCEALED PICK HOLES AND T SEAL CASSET.



Fond du Lac
First on the Lake

DEPARTMENT OF PUBLIC WORKS
ENGINEERING AND TRAFFIC DIVISION
CITY OF FOND DU LAC, WISCONSIN

SCALE: 1" = 2'
 DESIGNED AND DRAWN BY HW
 H:\HYDRO\City and County\DOT\City STD\PRECAST MANHOLE DETAIL.PDF

MANDREL FOR DEFLECTION TESTS

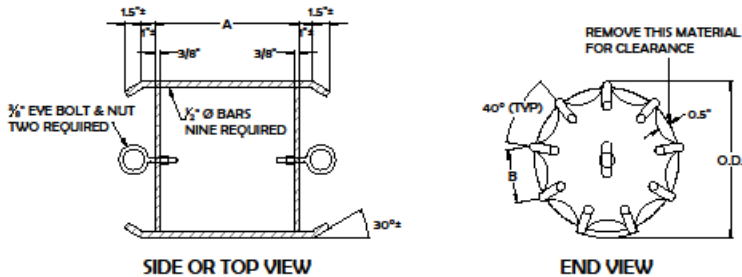

NOTE:
 1. TOLERANCE ON MANDREL O.D. IS ± 0.010 "

REQUIRED DIMENSIONS:
 1. MANDREL DIMENSIONS ON "O.D."
 2. 40° SPACING BETWEEN ANGLES
 3. DIMENSIONS A ARE MINIMUMS
 ALL OTHER DIMENSIONS ARE OPTIONAL

SUGGESTED MANDREL DESIGN

NOMINAL PIPE SIZE I.D.	A (MIN.)	MINIMUM MANDREL O.D. (INCHES)							
		DEFLECTION= D-3034 SDR-35				DEFLECTION= F-949			
		5%	B	7.5%	B	5%	B	7.5%	B
8"	8"	7.28	2.496	7.09	2.424	7.27	2.484	7.08	2.424
10"	10"	9.08	3.108	8.85	3.024	9.07	3.096	8.83	3.024
12"	10"	10.79	3.684	10.51	3.600				
15"	12"	13.20	4.512	12.85	4.392				
		F679 P546 12454C PIPE				F679 P546 12364C PIPE			
18"	15"	16.13	5.520	15.70	5.316	16.20	5.544	15.78	5.400
21"	18"	19.00	6.492	18.80	6.324	19.09	6.528	18.59	6.360
24"	21"	21.36	7.308	20.79	7.116	21.46	7.344	20.89	7.152
27"	24"	24.06	8.232	23.43	8.016	24.17	8.268	23.54	8.062

Fond du Lac
 First on the Lake

DEPARTMENT OF PUBLIC WORKS
 ENGINEERING AND TRAFFIC DIVISION
 CITY OF FOND DU LAC, WISCONSIN

SCALE: 1" = 2'
 REVISED 12/19 BY HSS
 A:\CITYWORK\Out 40 Drawings\DTL City 100-MANDREL FOR DEFLECTION TESTS.DWG

1-A-2

TRENCH SECTION (TYPICAL)

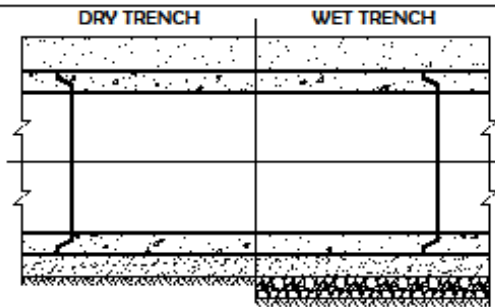
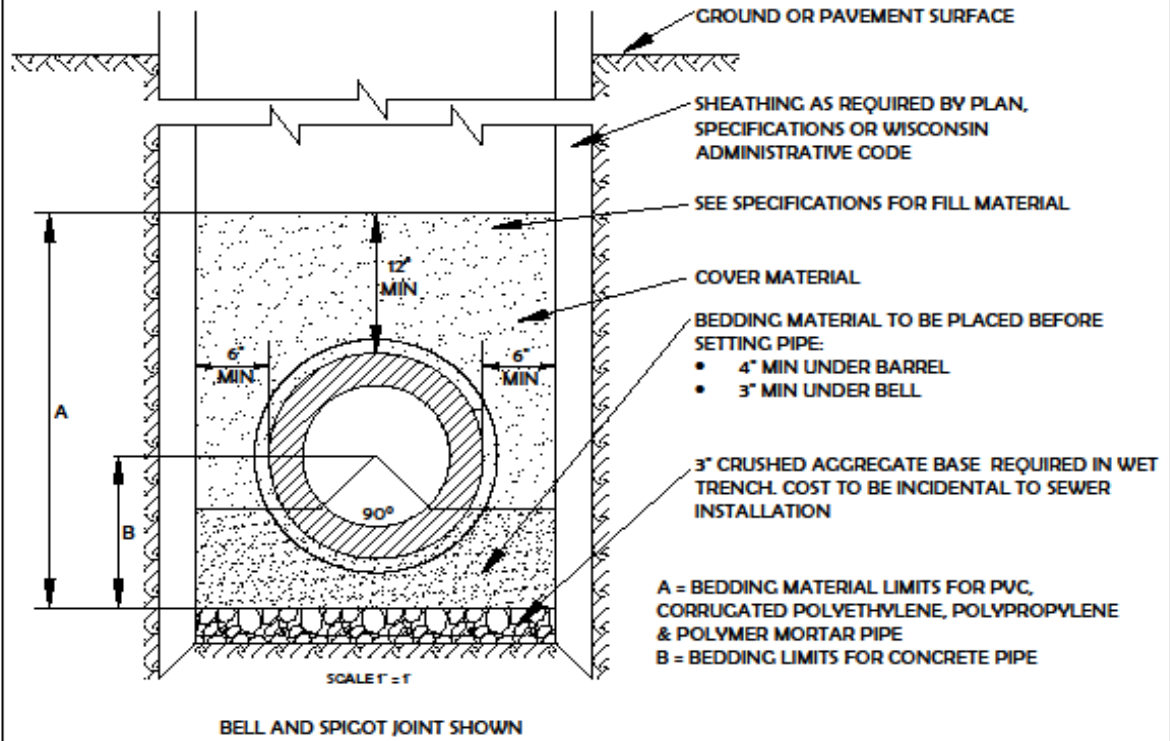

TONGUE AND GROOVE CROSS SECTION (EXAGGERATED)

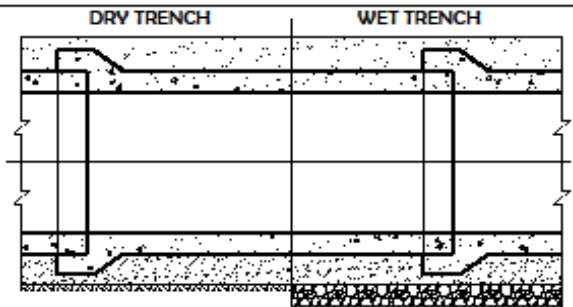

BELL AND SPIGOT CROSS SECTION (EXAGGERATED)

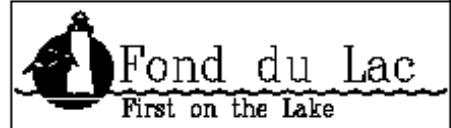

REVISED 02/27/14 BY NW
 J:\CIVIL\DWG\Civil 3D Drawings\DTL\City SDOs\TRENCH SECTION DETAIL.PDF

DEPARTMENT OF PUBLIC WORKS
 ENGINEERING AND TRAFFIC DIVISION
 CITY OF FOND DU LAC, WISCONSIN

DETAIL SPECIFICATION

SEWER CONSTRUCTION - PART 10

Sewer Construction Specifications

shall be in accordance with

Standard Specifications for Sewer and Water Construction in Wisconsin

Sixth Edition

December 22, 2003 with Addendum No. I December 22, 2004

and Excluding Part I - General Conditions

published by

Public Works Industry Improvement Program

2835 N. Mayfair Road

Milwaukee, WI 53222

414/788-1050

This page intentionally left blank.

DETAIL SPECIFICATION

TOPSOIL - PART 23

1. **WORK INCLUDED**

1.1. WORK under this item includes furnishing all labor, tools, equipment and materials necessary for topsoil placed on any area designated in the SPECIAL SPECIFICATIONS.

2. **MATERIAL**

2.1. Material for backfill shall be taken from excess material from subgrade excavation. This material shall be free from cinders, gravel, slag or broken stone.

3. **METHODS**

3.1. The area between the curb and sidewalk shall be backfilled with material specified in 2.1. After deposition of the material, it shall be graded and compacted to an elevation 4 inches below the finished elevation.

3.2. After backfilling, the graded material shall be covered with a 4 inch layer of topsoil. All lumps and clods in the topsoil shall be broken down by means of harrows, discs or other equipment to provide a uniformly textured soil. Rocks, twigs, large clods or other foreign material shall be removed and the entire surface raked to present a uniform appearance.

4. **MEASUREMENT AND PAYMENT**

4.1. Payment for topsoil under this item shall be made on a square yard basis and on the quantity as indicated in the BID. The price shall be full compensation for furnishing, excavating, loading, hauling and placing of topsoil and for undercutting of excavations or underfilling of embankments, and for furnishing all labor, materials, equipment, tools and incidentals necessary to complete the WORK.

This page was intentionally left blank.

DETAIL SPECIFICATION

SEEDING - PART 24

1. **WORK INCLUDED**

1.1. Work under this part shall include preparation of soil, and furnishing and sowing the required seed on areas designated on the DRAWINGS or SPECIFICATIONS.

2. **PREPARATION OF SEED BED**

2.1. The areas to be seeded shall be worked with discs, harrows, rakes, or other equipment until it becomes an even and loose seed bed in advance of the seeding.

3. **SEED MIXTURES**

3.1. Seed mixtures shall be composed of the purity, germination, and proportions by power as given below in the table.

SEEDS			MIXTURES		
Species	% Purity	% Germination	% in No. 1	% in No. 2	% in No. 3
Kentucky 31 Fescue	97	90	---	---	65
21# Kentucky Bluegrass	85	80	40	15	10
Creeping Red Fescue	97	80	30	55	15
Red Top	92	90	10	5	5
Perennial Ryegrass	98	90	5	10	5
White Clover	95	90	15	15	---

4. **MIXTURE TO BE USED**

4.1. Mixture No. 1 is intended for use on average loam, heavy clay or moist soils, at 1 1/2 pounds per 1000 square feet.

4.2. Mixture No. 2 is intended for use on light, dry, sandy or gravelly soils, at 2 pounds per 1000 square feet.

5. **SOWING**

5.1. Sowing shall be done by use of proper equipment and after seeding the area shall be lightly raked or dragged to cover the seed with approximately 1/4" of soil and then lightly rolled.

6. **MEASUREMENT AND PAYMENT**

6.1. Measurement shall be by the square yard and payment will be by contract unit price for the quantity stated in the BID and shall be full compensation for furnishing,

handling, and storing seed, for preparing seed bed and sowing the seed, and for all labor, tools, equipment and incidentals necessary to complete the work.